

# 5110

## ELECTRIC RIDE-ON FLOOR PREP SYSTEM INSTRUCTION MANUAL



 Read Manual Before Operating Machine



# Table of Contents

<b>Table of Contents</b> .....	<b>3</b>
<b>Features and Specifications</b> .....	<b>4</b>
<b>Safety</b> .....	<b>5-8</b>
General Rules for Safe Operation .....	5
Characteristics of a Defensive Operator .....	6
Grounding .....	6
Extension Cords .....	7-8
Hydraulic Safety Tips .....	8
Machine Operation .....	9-20
Power Box .....	9
Hydraulic Levers .....	9
Cylinder Lift .....	9
Operating Around The Cord.....	10
How To Plug In Cords .....	11
Loading/Unloading.....	13
Job Site Movement .....	14-15
Cutting Head & Blades .....	16-17
Blade Settings.....	18-19
Ditching.....	20
Blades.....	21-25
Blade Sharpening .....	22
<b>Machine Maintenance</b> .....	<b>26-34</b>
Slide Plate.....	26
Lower Cutting Head Support .....	26
Oil Level.....	27
Wheel Motor Change Out.....	27
Hose Change Out.....	28
Hydraulic Cylinder Change Out .....	29
Cord Guide .....	30
Remove Cord Guide .....	30
Wheel Changing .....	30
Changing Filter .....	30
Caster Maintenance.....	31
Back Up Beeper and Light.....	32
Seat Replacement .....	33
Seat Safety Switch.....	33
Debris Deflector Mounting Instructions.....	34
<b>Complete Parts List</b> .....	<b>35-36</b>
<b>Parts List and Diagram</b> .....	<b>37-52</b>
External Parts .....	37
Electrical Box Parts.....	38
Switch and Back-up Beeper Parts .....	39
Instruction Tube & Cord Guide Parts .....	40
Motor Parts .....	41
Pump Parts .....	42
Frame & Support Parts .....	43
Wheel Parts .....	44
Single Spool & Hose Parts .....	45
Double Spool & Hose Parts .....	46
Slide Plate & Cylinder Parts.....	47
Caster & Foot Peg Parts.....	48
Filter Parts .....	49
Weight Parts .....	50
Labels .....	51-52
<b>Accessories</b> .....	<b>53</b>
<b>Material Safety Data</b> .....	<b>54-57</b>
<b>Guarantee</b> .....	<b>59</b>

# Features and Specifications

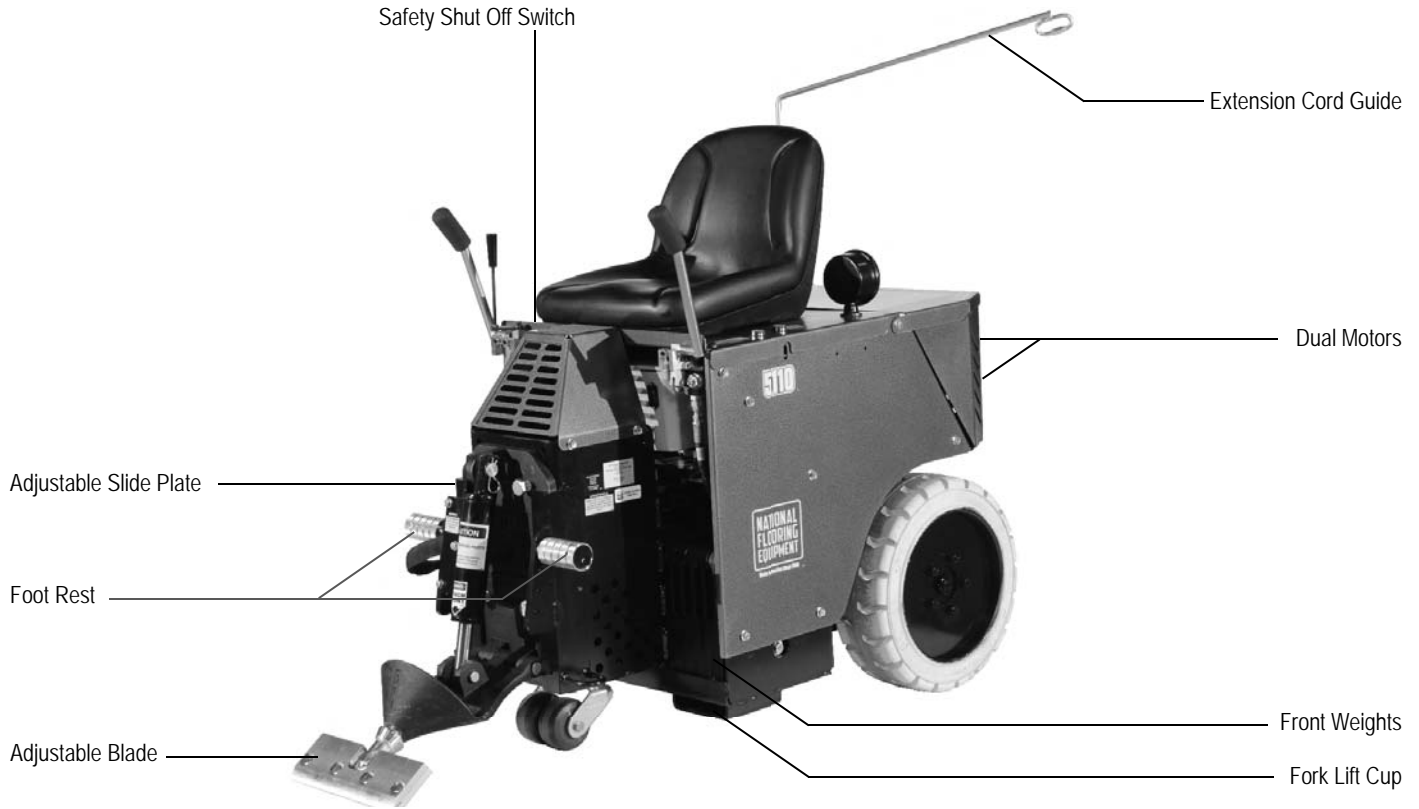

The electric ride-on floor removal machine is very maneuverable designed to work in confined areas. The 115 volt electric motor allows the machine to be operated on any job site.

## FEATURES

**Extension Cord Guide** - The cord guide is designed to keep track of the location of the electrical cord especially when backing up and turning.

**Adjustable Blade** - Adjustable blade pitch and angle.

**Safety Shut Off Switch** - Seat switch and E-Stop knob for safety.

**Front Weights** - Additional front weights creates additional downforce.

**Fork Lift Cup** - Easily accessible fork lift cups for easy loading and unloading.

**Foot Rest** - Adjustable foot pegs provide optimal comfort and ergonomics.

**Adjustable Slide Plate** - Affords maximum versatility in blade settings.

**Dual Motors** - 1.5 HP motors removes up to 34.4 m/min (113 ft/min).

**Rear Weight Compartment** - easily add additional down-pressure when required.

## Product Specifications

Width	Length	Height	Empty Weight	Fully Weighted	Removable Weight
62.2 cm (24.5")	132.1 cm (52")	125.7 cm (49.5")	539.7 kg (1190 lb)	664 kg (1465 lb)	158 kg (350 lb)
Run Time	HP	Speed	Sound Level	RPM	Voltage
8-12 hours	1.5	up to 34.4 m/min (up to 113 ft./min.)	94-97 dB(A)	1725	115

## GENERAL RULES FOR SAFE OPERATION

**READ AND SAVE ALL INSTRUCTIONS FOR FUTURE USE.** Before use, ensure operators reads and understand this manual. Read and understand labeling on machine and components. All operators must view the instruction video. Extra copies of the manual and video are available.

1. **KNOW YOUR EQUIPMENT:** Read this manual carefully to learn equipment applications and limitations, potential hazards associated with this type of equipment. Keep this manual with the equipment it is associated with.
2. **DISARM MACHINE:** Remove cutting head or drop cutting head to the floor when machine is not in use.
3. **DO NOT "SIDE HILL" MACHINE.**
4. **AVOID DANGEROUS ENVIRONMENTS:** Do not use in rain, damp or wet locations, or in the presence of explosive atmospheres (gaseous fumes, dust or flammable materials). Remove materials or debris that may be ignited by sparks.
5. **KEEP WORK AREA CLEAN AND WELL LIT:** Cluttered, dark work areas invite accidents.
6. **DRESS PROPERLY:** Do not wear loose clothing. These may be caught in moving parts. When working wear gloves and insulated non-skid footwear. Keep hands and gloves away from moving parts.
7. **USE SAFETY EQUIPMENT:** Proper eye protection should be worn at all times. Wear hearing protection during extended use and a dust mask for dusty operations. Hard hats, face shields, safety shoes, etc. should be worn when specified or necessary.
8. **KEEP BYSTANDERS AWAY:** Children and other bystanders should be kept at a safe distance from the work area to avoid distracting the operator and contacting the equipment or extension cord. Operator should be aware of the proximity of bystanders. This machine is not intended for use by persons (including children) with reduced physical, sensory or mental capabilities or lack of experience and knowledge.
9. **PROTECT OTHERS IN THE WORK AREA:** Provide barriers or shields as needed to protect others from debris.
10. **USE PROPER ACCESSORIES:** Using accessories that are not recommended may be hazardous. Be sure accessories are properly installed and maintained. Do not delete a guard or other safety device when installing an accessory or attachment.
11. **CHECK FOR DAMAGED PARTS:** Inspect guards and other parts before use. Check for misalignment, binding of moving parts, improper mounting, broken parts and other conditions that may affect operation. If abnormal noise or vibration occurs, turn off immediately and have the problem corrected before further use. Do not use damaged equipment. Tag damaged equipment "DO NOT USE" until repaired. Missing or damaged parts should be properly repaired or replaced immediately. For all repairs, use only identical National replacement parts.
12. **REMOVE ALL ADJUSTING KEYS AND WRENCHES:** Make a habit of checking that the adjusting keys, wrenches, etc. are removed from the tool before turning it on.
13. **GUARD AGAINST ELECTRIC SHOCK:** Prevent body contact with grounded objects such as pipes, radiators, ranges and any other related surfaces. When making cuts, always check the work area for hidden wires or pipes. Hold your equipment by insulated nonmetal grasping surfaces. Use a Ground Fault Circuit Interrupter (GFCI) to reduce shock hazards.
14. **AVOID ACCIDENTAL STARTING:** Be sure equipment is turned off before plugging in. Do not use equipment if the power switch does not turn the equipment On and Off.
15. **DO NOT FORCE EQUIPMENT:** Equipment will perform best at the rate for which it was designed. Excessive force only causes operator fatigue, increased wear and reduced control.
16. **KEEP HANDS AWAY FROM ALL CUTTING EDGES AND MOVING PARTS.**
17. **WEAR** gloves when changing accessories.
18. **DO NOT ABUSE CORD:** Never unplug by pulling the cord from the outlet. Pull plug rather than cord to reduce the risk of damage. Keep the cord away from heat, oil, sharp objects, cutting edges and moving parts.
19. **DO NOT OVERREACH. MAINTAIN CONTROL:** Keep proper footing and balance at all times. Maintain a firm grip.
20. **STAY ALERT:** Watch what you are doing and use common sense. Do not use when you are tired, distracted or under the influence of drugs, alcohol or any medication causing decreased control.
21. **STARTING MACHINE:** On/Off switch must be in off position before connecting to power source.
22. **UNPLUG EQUIPMENT:** When not in use and before changing accessories or performing recommended maintenance, unplug machine.
23. **MAINTAIN EQUIPMENT CAREFULLY:** Keep handles dry, clean and free from oil and grease. Keep cutting edges sharp and clean. Follow instructions for lubricating and changing accessories. Inspect equipment cords and extension cords for damage. Replace damaged parts. Use only identical National replacement parts.

# Safety

---

24. **STORE IDLE EQUIPMENT:** When not in use, store in a dry, secured place. Keep away from children.
25. **MAINTAIN LABELS AND NAMEPLATES:** These carry important information. If unreadable or missing, contact National for a replacement.
26. **MACHINE IS HEAVY, DO NOT DROP.** Ensure proper lifting procedures are followed when transporting.
27. **DO NOT USE ON STEPS.**
28. **DO NOT ALLOW** the cutting heads to come into contact with the supply cord.
29. **BATTERIES:** Periodically inspect batteries, charger and all plug connections. Only the manufacturer or an authorized servicing agent should replace the batteries. Do not open or tamper with batteries. Doing so voids all warranties and could cause injury due to electrical shock.
30. **REGULARLY EXAMINE** the supply cord for damage, such as cracking or aging. If damaged, replace the cord before further use. Only replace the supply cord with the type specified in this manual.

## CHARACTERISTICS OF A DEFENSIVE OPERATOR

A Good Operator is a "Defensive" Operator!

### QUALITIES INCLUDE:

**Education:** Acquires knowledge of the machine, jobsite condition and the surrounding environment.

**Alert:** Stays alert at all times and never lets guard down.

**Skills:** Only performs duties they are qualified to do. Continually tries to improve.

**Judgment:** Use sound judgement and does not take careless chances.

**Common Sense:** Applies knowledge in practical situations.

**Recognizes the Hazards:** Maintains alertness and anticipates danger.

**Understands the Defense:** Knows that safety isn't an accident. A person must choose to follow a forward-thinking mind set.

**Acts Correctly:** Does not give in to peer pressure. Performs correctly when supervised or not.



**WARNING: SILICA DUST WARNING** GRINDING/CUTTING/DRILLING OF MASONRY, CONCRETE, METAL AND OTHER MATERIALS CAN GENERATE DUST, MISTS AND FUMES CONTAINING CHEMICALS KNOWN TO CAUSE SERIOUS FATAL INJURY OR ILLNESS, SUCH AS RESPIRATORY DISEASE, CANCER, BIRTH DEFECTS OR OTHER REPRODUCTIVE HARM. IF YOU ARE FAMILIAR WITH THE RISKS ASSOCIATED WITH THE PARTICULAR MATERIAL BEING CUT, REVIEW THE MATERIAL SAFETY DATA SHEET AND/OR CONSULT YOU EMPLOYER, THE MATERIAL MANUFACTURER/SUPPLIER, GOVERNMENTAL AGENCIES SUCH AS OSHA AND NIOSH AND OTHER AUTHORITIES ON HAZARDOUS MATERIALS. CALIFORNIA AND SOME OTHER AUTHORITIES, FOR INSTANCE, HAVE PUBLISHED LISTS OF SUBSTANCES KNOWN TO CAUSE CANCER, REPRODUCTIVE TOXICITY, OR OTHER HARMFUL EFFECTS. CONTROL DUST, MIST AND FUMES AT THE SOURCE WHERE POSSIBLE. IN THIS REGARD USE GOOD WORK PRACTICES AND FOLLOW THE RECOMMENDATIONS OF THE MANUFACTURER/SUPPLIER, OSHA/NIOSH, AND OCCUPATIONAL AND TRADE ASSOCIATIONS. WHEN THE HAZARDS FROM INHALATION OF DUST, MISTS AND FUMES CANNOT BE ELIMINATED, THE OPERATOR AND ANY BYSTANDERS SHOULD ALWAYS WEAR A RESPIRATOR APPROVED BY OSHA/MSHA FOR THE MATERIAL BEING CUT.

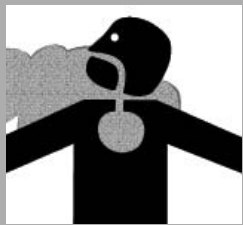

## GROUNDING

Jobsite receptacles can vary. Check the voltage at different receptacles on the jobsite for a more accurate voltage reading. 15 amp GFI outlets are not recommended.

### GROUNDED TOOLS: TOOLS WITH THREE PRONG PLUGS

Equipment marked "Grounding Required" have a three wire cord and three prong grounding plug. The plug must be connected to a properly grounded outlet (Figure A). If the equipment should electrically malfunction or break down, grounding provides a low resistance path to carry electricity away from the user; reducing the risk of electric shock.

The grounding prong in the plug is connected through the green wire inside the cord to the grounding system in the equipment. The green wire in the cord must be the only wire connected to the equipment's grounding system and must never be attached to an electrically "live" terminal.



**WARNING:** ELECTRICAL CORDS CAN BE HAZARDOUS. MISUSE CAN RESULT IN FIRE OR DEATH BY ELECTRICAL SHOCK. READ CAREFULLY AND FOLLOW ALL DIRECTIONS.

## GROUNDING

Jobsite receptacles can vary. Check the voltage at different receptacles on the jobsite for a more accurate voltage reading.



**CAUTION:** IMPROPERLY CONNECTING THE GROUNDING WIRE CAN RESULT IN THE RISK OF ELECTRIC SHOCK. CHECK WITH A QUALIFIED ELECTRICIAN IF YOU ARE IN DOUBT AS TO WHETHER THE OUTLET IS PROPERLY GROUNDED. DO NOT MODIFY THE PLUG PROVIDED WITH THE EQUIPMENT. NEVER REMOVE THE GROUNDING PRONG FROM THE PLUG. DO NOT USE THE EQUIPMENT IF THE CORD OR PLUG IS DAMAGED. IF THE PLUG WILL NOT FIT THE OUTLET, HAVE A PROPER OUTLET INSTALLED BY A QUALIFIED ELECTRICIAN.

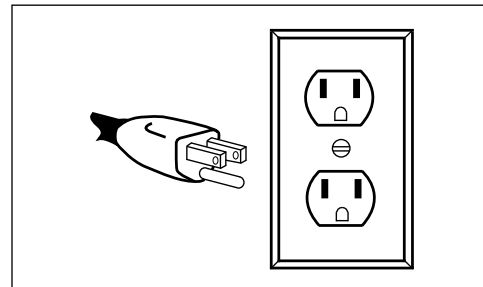

FIG. A

## GROUNDING TOOLS: TOOLS WITH THREE PRONG PLUGS

Equipment marked "Grounding Required" have a three wire cord and three prong grounding plug. The plug must be connected to a properly grounded outlet (Figure A). If the equipment should electrically malfunction or break down, grounding provides a low resistance path to carry electricity away from the user; reducing the risk of electric shock.

The grounding prong in the plug is connected through the green wire inside the cord to the grounding system in the equipment. The green wire in the cord must be the only wire connected to the equipment's grounding system and must never be attached to an electrically "live" terminal.

The equipment must be plugged into an appropriate outlet, one which is properly installed and grounded in accordance with all codes and ordinances. The plug and outlet should look like the example in Figure A.

## GUIDELINES FOR USING EXTENSION CORDS

- If you are using an extension cord outdoors, make sure it is marked with the suffix "W-A" ("W" in Canada) to indicate that it is acceptable for outdoor use.
- Be sure your extension cord is properly wired and in good electrical condition. Always replace a damaged extension cord or have it repaired by a qualified person before using it.
- Protect your extension cords from sharp objects, excessive heat and damp or wet areas.
- Keep away from water. Do not use if wet.
- Inspect thoroughly before each use. **DO NOT USE IF DAMAGED.**
- Make sure equipment is not running before disconnecting cord.
- FULLY INSERT plug into outlet.
- Do not remove, bend or modify any metal prongs or pins of cord.
- Do not use excessive force to make connections.
- Do not connect a three prong plug to a two-hole cord.
- Avoid overheating. Uncoil cord and do not cover it with any material.
- Do not walk on cord.
- Do not drive, drag or place objects over cord.

# Safety

---

- Regularly examine the supply cord for damage, such as cracking or aging. If damage is found, replace the cord before further use.
- Only replace the supply cord with the type specified in the instruction manual.

## HYDRAULIC SAFETY TIPS

### MAINTAINING A SAFE WORK ENVIRONMENT

Establishing a safe working environment in and around your hydraulic equipment is just common sense. The easiest and most effective way to avoid problems is to make sure associates understand their equipment, know how to operate it safely and recognize the danger it represents if handled carelessly. A few things you must be aware of include:

1. **PRESSURE:** Hydraulic fluid under pressure is dangerous and can cause serious injury.
2. **FLAMMABILITY:** When ignited, some hydraulic fluids can explode and/or cause fires.
3. **MECHANICAL:** Hydraulic fluid creates movement, which causes parts of your equipment to move or rotate. Always be aware of what you are doing.
4. **MOISTURE:** Use caution when operating in wet or high moisture conditions. Make sure all electrical fittings, switches, cords plus stain reliefs are in good condition. Always unplug when not in use and when doing any service work.
5. **ELECTRICAL:** Faulty wiring can also be an electrical hazard. A regular preventive maintenance program should always include a wiring check. Unplug batteries and/or charger before serving.
6. **TEMPERATURE:** Because this machine operates at a relatively low pressure, overheating is not common. If surface of tank becomes too hot to touch by hand (above 55° C, 125° F), shut off machine and allow to cool off.

### PRESSURE

Our system runs at or below 3,000 psi. Never look for a leak when unit is under pressure. Using your hand could cause serious injury. A few common ways to encounter hydraulic fluid under pressure include:

1. **PINHOLE:** Fluid under pressure can cause serious injury. It can be almost invisible escaping from a pinhole, and it can pierce the skin into the body. Do not touch a pressurized hydraulic hose assembly with any part of your body. If fluid punctures the skin, even if no pain is felt, a serious emergency exists. Obtain medical assistance immediately. Failure to do so can result in loss of the injured part or death.
2. **LEAK:** Keep fittings and hoses tight. Only check and service when not under pressure. Leaking hydraulic fluid is not only unsightly, it's hazardous. In addition to making workplace floors slippery and dangerous, leaks also contaminate the environment. Before cleaning an oil spill, always check EPA, state and local regulations.
3. **BURST:** Whether due to improper selection or damage, a ruptured hose can cause injury. If it bursts, a worker can be burned, cut, injected or may slip and fall.
4. **COUPLING-BLOW OFF:** If the assembly is not properly made or installed, the coupling could come off and hit or spray a worker, possibly resulting in serious injury. Never operate machine without guards.

### FLAMMABILITY

With the exception of those comprised primarily of water, all hydraulic fluid is flammable when exposed to the proper conditions (including many "fire-resistant" hydraulic fluids).

Leaking pressurized hydraulic fluids may develop a mist or fine spray that can flash or explode upon contact with a cause of ignition. These explosions can be very severe and could result in serious injury or death.

Precautions should be taken to eliminate all ignition sources from contact with escaping fluids, sprays or mists resulting from hydraulic failures. Sources of ignition could be electrical discharges (sparks), open flames, extremely high temperatures, sparks caused by metal-to-metal contact, etc.

### HYDRAULIC FLUID

Only use Texaco Rando 46 Hydraulic Oil or Compatible Fluid like IS032. Non-compatible fluids could cause damage to unit or serious injury.

# Machine Operation

## POWER BOX (FIGURE B)

Note: It is necessary to be seated before starting machine to keep machine running. The two green switches are the starting switches. Press one green switch at a time. This will start the motors individually. The red switch is the shut off switch, also referred to as the "kill switch". See cord hook up for plugging in the motor cords.

## HYDRAULIC LEVERS (FIGURE C)

The hydraulic levers steer the machine. They are feathered spool valves. For smooth even movement, move levers slowly. Fast movement on control levers will result in jerky, uneven movement.

- Move levers slowly.
- Both levers forward **↑↑** move the machine forward.
- Both levers backward **↓↓** move the machine backward.
- The left lever forward and the right lever backward **↑↓** turn the machine quickly to the right.
- The left lever backward and the right lever forward **↓↑** turn the machine quickly to the left.
- Only the left lever forward **↑**, turns the machine slowly to the right.
- Only the left lever backwards **↓**, turns the machine slowly to the left.

## CYLINDER LIFT (FIGURE D)

The cylinder lift lever raises and lowers the cylinder and cutting head. After setting slide plate to proper height, use the cylinder lift lever to set blade to proper cutting angle. Pull back **↓** on the cylinder lift lever to raise the cutting head. Push the cylinder lift lever forward **↑** to lower the cutting head. Continuing to push the cylinder lift lever forward and it will adjust the angle of the cutting head. This will also jack up the machine (See Figure E). This will need to be done when doing maintenance on the machine (ie: wheel changing, front caster maintenance etc).



FIG. B



FIG. C



FIG. D



FIG. E



**WARNING:** DISARM MACHINE BY REMOVING THE CUTTING HEAD OR DROPPING THE CUTTING HEAD TO THE FLOOR WHEN THE MACHINE IS NOT IN USE.

# Machine Operation



FIG. F

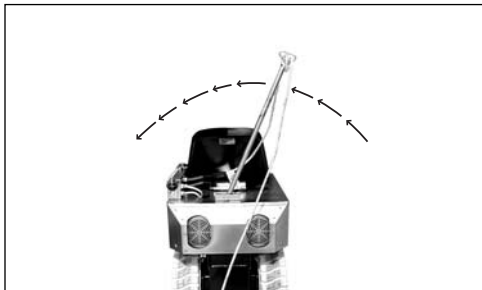

FIG. G



FIG. H



**CAUTION:** DO NOT RUN OVER CORD. DOING SO COULD CAUSE DAMAGE TO EQUIPMENT OR SEVERE BODILY INJURY.

## OPERATING AROUND THE CORD (FIGURE F)

The extension cord should be properly fed through the clip on the end of the flip arm cord guide. Loop cord once. See the Cord Hook Up in the manual. The flip arm cord guide is designed to keep track of the location of the electrical cord, especially when backing up and turning.

- Keep cord to side and slightly forward.
- Always work away from the cord.
- When backing up or making a sharp turn, check the location of the cord.
- Flip arm moves from side to side to help to keep electrical cords from being ran over (See Figure G).
- Adjust the flip arm cord guide in confined areas. Center position is achieved by moving cord guide arm to the 12 o'clock position and securing in place with pin (See Figure H). This is used when going through doorways or hallways. Hold cord straight out the back of the machine.



**WARNING:** DISARM MACHINE BY REMOVING THE CUTTING HEAD OR DROPPING THE CUTTING HEAD TO THE FLOOR WHEN THE MACHINE IS NOT IN USE.

## CASTER

Keep clean and free of debris, make sure it can move freely.

## FOOT PEG

Keep feet resting and secured on foot pegs when operating machine.

## SEAT SAFETY SWITCH

The seat safety switch is mounted under the center portion of the seat. This switch is designed as an emergency shut off. If you are not sitting down on the seat, the machine will shut off. Warning: Do not alter switches.

## DISARM MACHINE

Remove blade or drop cutting head to the floor when machine is not in use.

## DISCONNECT MACHINE FROM POWER

Never change cutting head or service blade while machine is running.

## LEAKAGE

Keep fittings and hoses tight. If a leak is noticeable, retighten fitting. If leakage persists, remove the connection and inspect.

## POWER CORD

Be aware of where the power cord is. Do not run over the cord. If an electrical cord is damaged it must be replaced by the manufacturer or its service agent or a similarly qualified person in order to avoid a hazard.

## ANGLE OF THE HEAD IS SET STEEP

When raising the front of the machine to a steep angle, the bottom of the slide plate should be raised so it is higher or even with the bottom of the guide channels.

## HOW TO PLUG IN CORDS



**WARNING:** ELECTRICAL CORDS CAN BE HAZARDOUS. MISUSE CAN RESULT IN FIRE AND/OR DEATH BY ELECTRICAL SHOCK. READ CAREFULLY AND FOLLOW ALL DIRECTIONS. NEVER DEFEAT SAFETY FEATURES OR BYPASS THE ELECTRICAL CONTROL BOX. DOING SO COULD CAUSE PROPERTY DAMAGE AND/OR SERIOUS INJURY.

### SIZE & GAUGE OF EXTENSION CORD

Grounded tools require a three wire extension cord. As the distance from the supply outlet increases, you must use a heavier gauge extension cord. Using extension cords with inadequately sized wire causes a serious drop in voltage, resulting in loss of power and possible equipment damage or circuit breaker failure.

- Two extension cords are required to run the machine.
- Extension cord specifications for EU; cord must have nominal cross-sectional area of 1.5 mm<sup>2</sup> and be polyvinyl chloride H05VV-F (227 IEC 53) or polychloroprene H05RN-F (245 IEC 57) or higher.

### CORD HOOK-UP

1. Connect both male motor cord plugs (from the back of the machine) into the female plugs on the back of the power control box (See Figure I). Each plug controls a motor and they can be plugged in either order. Make sure cords are tightly plugged together.
2. From the female end of the twin cord, go in 1 meter and make a loop in the cord. Insert the loop into the clip on the end of the flip-arm/cord guide. The loop in the cord secures the cord from slipping or pulling out of the cord guide.
  - For 115 volt; connect both female plugs into the male plugs on the side of the power control box (See Figure J). Also, see "Outlet Testing" before plugging cords into outlet. Make sure cords are tightly plugged together.



FIG. I



FIG. J

# Machine Operation

---

## OUTLET TESTING

If cords are plugged into the same outlet, start one motor at a time. Never start both motors at the same time. If you can't run both motors from the same outlet, plug the twin cord into the supplied extension cords and test in two separate circuits. Choose outlets as far apart as is practical. The idea is to find outlets on different circuits.

## CORD LENGTH

Extension cord specifications for EU; cord must have nominal cross-sectional area of 1.5 mm<sup>2</sup> and be polyvinyl chloride H05VV-F (227 IEC 53) or polychloroprene H05RN-F (245 IEC 57) or higher.



**WARNING:** IF THE SUPPLY CORD IS DAMAGED, IT MUST BE REPLACED BY THE MANUFACTURER OR ITS SERVICE AGENT OR A SIMILARLY QUALIFIED PERSON IN ORDER TO AVOID A HAZARD.

# Machine Operation

## LOADING/UNLOADING

- Always remove blade and cutting head when machine is being moved or transported.
- Cutting head and slide plate can be removed to make the machine more compact.
- NEVER leave machine unattended on an incline.
- Removing added weights help to make the machine easier and safer to move in and out of a vehicle.

## DOCK HEIGHTS

It is best to load or unload the machine from a level/equal dock height (a van from a van dock height, a truck/semi from a regular dock height).

## POWER-GATE

A power-gate can be used when the dock height is not available. Make certain the machine is secure so it does not roll off the power-gate. To better secure machine, raise machine on to the lower cutting head support raising machine off the caster.

## RAMPS

To be safe, the ramp needs to be very long to accommodate the machine being loaded/unloaded. Remove added weight. Make sure ramp is secured. Do not have at a steep incline. The use of a power winch or hand come-a-long is much safer. For a van, the ramp should be 12 to 18 feet (3.6 to 5.5 m) in length depending on the depth of the incline. For truck height taller than a van, longer ramps will be needed. See OSHA guidelines. It is not recommended to drive the machine, connected with power, on a ramp. Make sure ramp is secure and has good contact before using. Failure to do so could cause ramp to fall away from the vehicle.

**Note:** See correct and safe operating angles and center of gravity on Page 14.

## FORKLIFT CUPS

There are two forklift cups mounted under the front of the machine (See Figure L). Slide fork lift forks through forklift cups. Slide forks all the way back to touch the rear tire (See Figure M). Before lifting machine, secure machine to fork lift with heavy 3000 lb (1365 kg) or heavier rope or chain. Tilt forks back to lift machine (See Figure N).

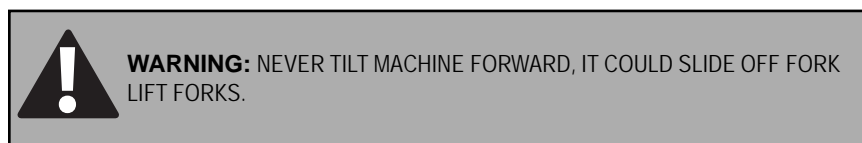

## WINCHES

Winches should be used for safety when loading or unloading with ramps. 3000 lb (1365 kg) winch minimum.

## TRANSPORTING

Secure machine down with ratchet straps when transporting the machine. To keep machine from rolling, hydraulic levers should not be locked in the forward or backward position. Hydraulic levers should be straight up in the "neutral" position. This helps to lock drive wheels. Lift machine off swivel caster onto lower cutting head support for better stabilization. Proper securing straps need to be rated at least twice the weight of the machine.

## WHEEL CHOCKS

Wheel chocks will help to secure the machine but DO NOT use wheel chocks alone to secure the machine.

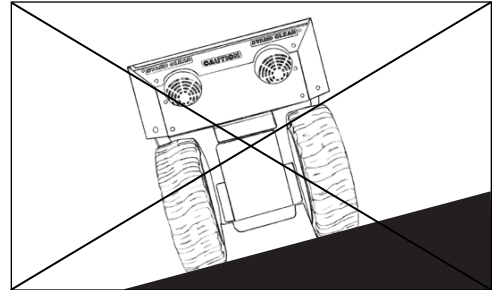

**FIG. K**  
Do Not Side Hill



**FIG. L**



**FIG. M**

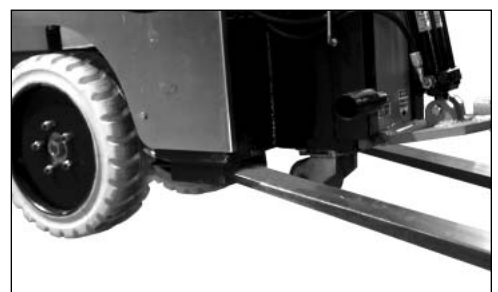

**FIG. N**

# Machine Operation

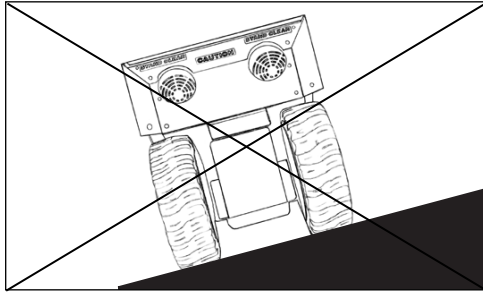

FIG. O

## CENTER OF GRAVITY

Be aware of your surroundings and machines operating angles. When changing from a low slide plate to a high slide plate setting or a low cutting head angle to a high cutting head angle, the operating "attitude" of the machine changes. When a floor surface is not level (ramps, inclines, large amounts of debris which would lift the drive wheel of the machine, etc.), the center of gravity changes. Too much of an angle could make the machine unsafe (a cause for tip-over). Do Not run the machine in unsafe environments.

## JOB SITE MOVEMENT

Always remove blade and cutting head when machine is being moved or transported

Cutting head and slide plate can be removed to make the machine more compact.

NEVER leave machine unattended on an incline.

Removing added weights help to make the machine easier to move.

## TAPING WHEELS

Taping the wheels with a wide like masking tape helps to prevent damage and dirt to floors during move-in and move-out.

## PALLETIZING

Only use a solid platform pallet. If a solid platform pallet is not available, place a piece of  $\frac{3}{4}$ " plywood on top of a pallet. Using a forklift with the forks inserted in the forklift cups, place machine on pallet. Use ratchet straps to secure machine to pallet.

## FRONT WHEEL ASSEMBLY (FIGURE S)

The front wheel assembly allows machine stability and safe transportation over any surface. It is easy and quick to attach or detach. Raise slide plate so the bottom of the slide plate is higher or even with the bottom of the guide channels. Raise cylinder, insert Front Wheel Assembly into cutting head. Secure with securing pin.

Note: Make sure the plate is parallel with the floor so the caster swivels freely.

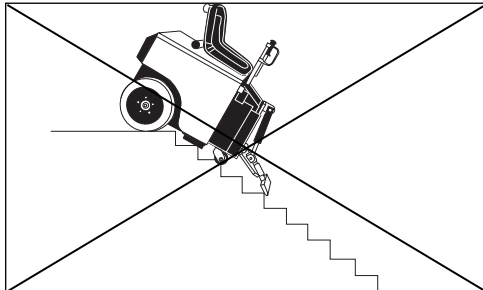

FIG. P

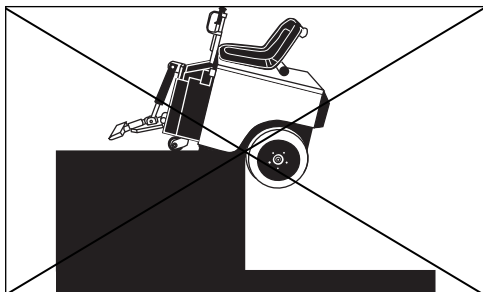

FIG. Q

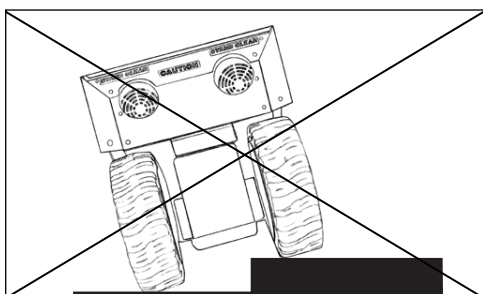

FIG. R



FIG. S

# Machine Operation

## TO MOVE MACHINE WITHOUT POWER (PUSHING MACHINE)

**Forward:** To move the machine forward, levers need to be pushed forward. To lock levers in place, connect a bungee-strap from each lever (pushing levers forward), pulling straps down to and connecting to the front plate (See Figure T).

**Backward:** To move machine backward, levers need to be pulled backwards. To lock levers in place, connect a bungee-strap from each lever (pushing levers backward), Pulling straps to the back of the machine and connecting behind the seat or the rear of the machine (See Figure U).

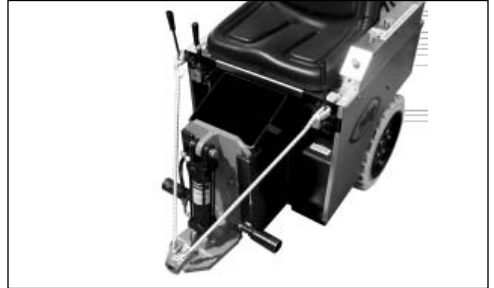

FIG. T



**WARNING:** ALWAYS REMOVE STRAPS BEFORE STARTING MOTORS. FAILURE TO DO SO WILL MAKE MACHINE MOVE AND MAY CAUSE PROPERTY DAMAGE AND/OR BODILY INJURY.

## ADJUSTING FLIP ARM CORD GUIDE IN CONFINED AREAS

In a hallway or confined area, center the flip arm cord guide to the twelve o'clock position so it is standing straight up (See Figure V). Secure with securing pin.



FIG. U



**WARNING:** WHEN DOING MAINTENANCE OR CHANGING A WHEEL, MAKE SURE MACHINE IS SUPPORTED PROPERLY OR SERIOUS INJURY COULD OCCUR.



FIG. V

# Machine Operation

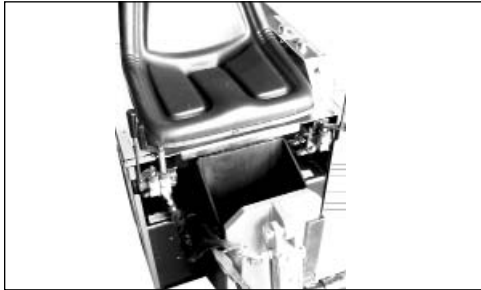

FIG. W

## FRONT WEIGHT

Adding weight to the front of the machine is necessary for difficult to remove goods such as, VCT, VAT, ceramic, thin-set or wood. Machine includes nine 16 kg front weights. Set front weights in front weight compartment (See Figure W).

## REAR WEIGHT

Adding rear weight creates more traction. The heavier the machine, usually the better it will work, especially on hard to remove goods.

Machine includes one 45 kg rear weight. Slide back weight in provided pocket under rear cowl (See Figure X). Secure locking bolt with either a 9/16 or 3/4 wrench (size varies).



FIG. X

**WARNING:** A HEAVY MACHINE CANNOT BE USED ON WOOD SUBFLOORS OR RAISED PANEL COMPUTER FLOORS, (KEEP MACHINE LIGHT). ALWAYS CHECK FLOOR FOR PROPER STRENGTH TO SUPPORT THE WEIGHT OF THE MACHINE.

**WARNING:** REMOVE ADDED WEIGHT FROM MACHINE BEFORE TRANSPORTING OR LOADING MACHINE. FAILURE TO DO SO COULD CAUSE LOSS OF CONTROL OF MACHINE, DAMAGE TO MACHINE OR PROPERTY AND BODILY INJURY.



**Low Setting:** Slide plate 1" off the floor. The lower the better. This is for normal to difficult removal.

FIG. Y

## CUTTING HEAD & BLADES

### DIALING IN THE MACHINE

Dialing in the machine is matching the correct cutting head, blade size, blade angle and added weight to the machine to make the material removal as easy as possible. For every material being removed, there is an optimum blade width, thickness, sharpness, angle and bevel (bevel up or bevel down).

### SAVING TIME WITH EXTRA CUTTING HEADS

The machine is supplied with one cutting head. Having additional cutting heads will save time on the job. Insert blades into the extra cutting heads before starting a job. When the blade is dull, instead of taking the time to replace it or sharpen it on the job, take out the cutting head and replace it with another. Or when a different type or size of blade is needed, you have them ready to use.

### ADJUSTING SLIDE PLATE AND CUTTING HEAD (FIGURE Y & Z)

Caution: Pinch point. When adjusting slide plate, keep feet and hands out from underneath the cutting head and slide plate. Failure to do so could cause severe bodily injury. When bolts are removed from the slide plate, the cutting head and the slide plate will drop down to the floor.

- Loosen the two bolts on the front of the slide plate with a 3/4" wrench (See Figure AA).
- Slide plate up or down to achieve the desired height of the cutting head.
- Firmly retighten both bolts.

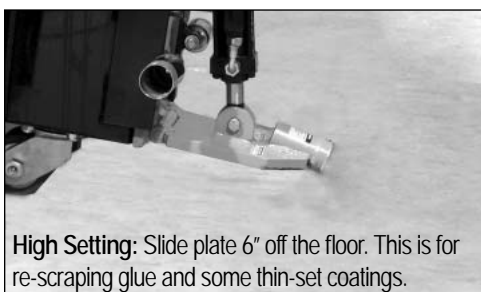

**High Setting:** Slide plate 6" off the floor. This is for re-scraping glue and some thin-set coatings.

FIG. Z

### SHEAR POINT

The shear point is the point where material to be removed will cut cleanly from the floor. If the blade is too wide or too dull, the shear point is lost.

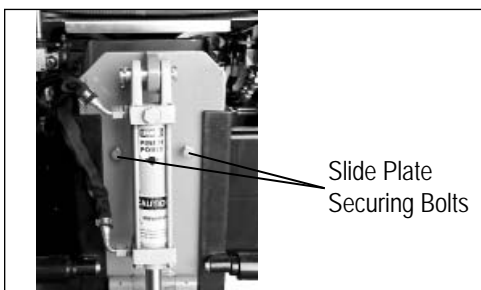

Slide Plate Securing Bolts

FIG. AA

**CAUTION:** BLADES ARE SHARP, USE EXTREME CAUTION. NEVER CHANGE CUTTING HEAD OR SERVICE BLADES WHILE MACHINE IS RUNNING.

# Machine Operation

## WEIGHT VS. SHARPNESS

The most common way to compensate for a dull blade is to add more weight and raise the blade angle (see re-scrape setting on Page 19). Weight allows dull blades to be used to a point. Weight also causes blades to dull and break easier. Blades of any thickness tend to catch cracks and expansion joints and will bend or break the blade if set at a high angle. For best results, run a small ditching blade at a low angle to identify as many cracks and joints as possible. If blades are breaking, you are misunderstanding the conditions.

## CUTTING HEAD ANGLE

Set the cutting head angle to where the material comes up the easiest.

## STEEP CUTTING HEAD ANGLE

A steep angle is only used for re-scraping. The slide plate has to be raised so the bottom of the slide plate is higher or even with the bottom of the guide channels (See Figure BB). Not raising the slide plate when operating the machine at a steep angle will cause the machine to jump and buck. It does not give the operator a clear vision of the cutting head and it raises the machine to operate at a unsafe operating height (See Figure CC). Failure to raise the slide plate could cause machine damage and/or bodily injury.

## SWIVEL HEAD

The swivel head keeps the blade in contact with the floor even when the floor is uneven. When using a flat blade, by swiveling the head over 180° allows another sharp edge on the blade without having to replace the blade.

## SAVING TIME WITH EXTRA CUTTING HEADS

The machine is supplied with one cutting head. Having additional cutting heads will save time on the job. Insert blades into the extra cutting heads before starting a job. When the blade is dull, instead of taking the time to replace it or sharpen it on the job, take out the cutting head and replace it with another. Or, when a different type or size of blade is needed, you have them ready to use.

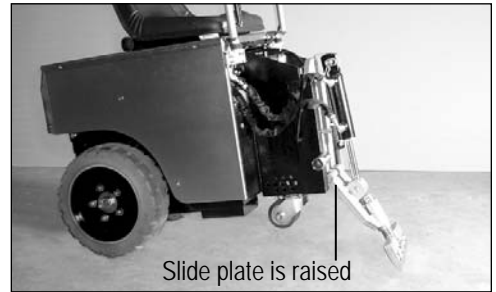

**FIG. BB**

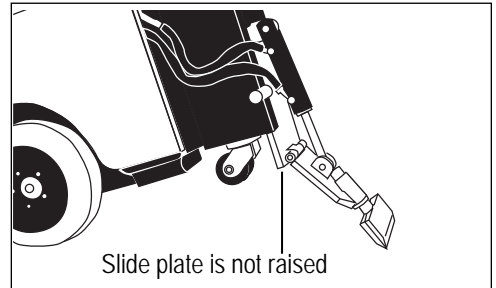

**FIG. CC**

# Machine Operation

## CUTTING HEAD INSERTION

Insert desired cutting head into cutting head holder. Secure with cutting head clip.

## SHANK BLADE INSERTION

Shank blades do not require a cutting head. Insert desired shank blade into cutting head holder. Secure with cutting head clip.

## BLADE SETTING

- Dull blades greatly reduce cutting ability. Re-sharpen or replace as needed.
- Proper blade size and placement, depending on material and sub-floor type, affects performance.
- The harder a job comes up, for best results, use a smaller blade.
- Start with a narrow blade, then increase blade size to optimize cutting pass. Narrower blades work easier than wider blades and usually clean the floor better. Wider is not always better or faster.
- Normally bevel on blade is up for concrete. Bevel down for wood and shoe blades for soft sub-floors.



**BEVEL DOWN OR  
SHOE BLADES  
WOOD FLOORS**



**BEVEL UP  
CONCRETE FLOORS**

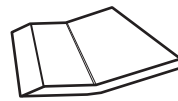

**SHOE BLADE  
SOFT SUB-FLOORS**

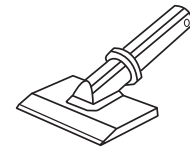

- KEEP BLADES SHARP.
- Dull blades greatly affect the performance of the machine and reduce cutting ability, resharpen or replace as needed.
- Keep your work area clean and clear of debris.
- After you have removed a portion of material, remove it out of the way. This will give the machine maximum performance and help to keep the work area safe.
- Always wear gloves when handling blades.

## SELF SCORING BLADES

Instead of pre-scoring a job, the self scoring blades automatically do the scoring.

## BLADE INSERTION OR BLADE CHANGING

Using a 3/4" socket wrench, loosen bolts on cutting head. Quantity of bolts will vary depending upon cutting head size. Insert blade into the cutting head to back of notch (See Figure DD). Tighten firmly.

Note: A cordless 3/8" drive impact wrench will speed up this process especially out on the job.

- Sharp blades are imperative for good performance.
- Always wear gloves when handling blades.

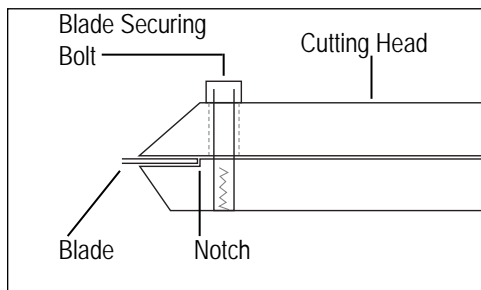

**FIG. DD**



**CAUTION:** BLADES ARE SHARP, USE EXTREME CAUTION. NEVER CHANGE CUTTING HEAD OR SERVICE BLADES WHILE MACHINE IS RUNNING.



**WARNING:** DISARM MACHINE WHEN MACHINE IS NOT IN USE. REMOVE THE CUTTING HEAD OR DROP CUTTING HEAD TO THE FLOOR. FAILURE TO DO SO COULD CAUSE SEVERE BODILY INJURY.

## BLADE SETTING

### CERAMIC SET-UP

Slide plate should be set low, 2.5 cm (1") off the floor. Use a Shank Blade or a Shank Blade with a carbide tip.

### WOOD SET-UP

Slide plate should be set low, 2.5 cm (1") off the floor. Use Shank Blades, Shank Blades with carbide tips or a 15.25 to 20.3 cm (6" or 8") Cutting Head with Shoe Blades, Bent Shoe Blades or Heavy Duty Blades. Note: run machine 45° to the grain of the wood.

### SECONDARY BACKING CARPET SET-UP

Slide plate should be set low, 2.5 cm (1") off the floor. Use a Cutting head from 25.4 to 68.6 cm (10" to 27") with Heavy Duty Blades or a Cutting Head from 25.4 to 35.5 cm (10" to 14") with a Self-Scoring Blade.

### FOAM BACK CARPET SET-UP

Slide plate should be set low, 2.5 cm (1") off the floor. Use Cutting Heads from 25.4 to 35.5 cm (10" to 14") with Self-Scoring Blades. If it is not stuck tight, use a Cutting Head from 35.5 to 38.6 cm (14" to 27") with a Standard Blade.

### DOUBLE STICK CARPET SET-UP

It is best to test to see which is the easiest way to remove double stick. Start with a Cutting Head from 25.4 to 35.5 cm (10" to 14") with Self-Scoring Blades. If Self Scoring blades do not work, score thru the carpet (See Figure JJ) the width of the blade (Standard Blade) and scrape up. In some cases, carpet might pull off the pad and then scrape up the pad separately.

### VCT TILE SET-UP

Slide plate should be set low, 2.5 cm (1") off the floor. If goods come up easily, try a razor blade with a Cutting Head from 20.3 to 35.5 cm (8" to 14"). If goods come up harder, use a Cutting Head from 20.3 to 68.6 cm (8" to 27") with a Premium High Tempered Blade to match cutting head size. If goods remove easily, a Tile Box #7074 can be used. A tile box also works for wind rowing and assists for a fast clean-up and collection of tile debris for quick removal.

### RUBBER TILE SET-UP

Slide plate should be set low, 2.5 cm (1") off the floor. Use a Cutting Head from 15.25 to 35.5 cm (6" to 14") with self-scoring blades.

### RE-SCRAPING SET-UP

Slide plate should be set high, 15.25 cm (6") off the floor. Use a Cutting Head from 20.3 to 35.5 cm (8" to 14") with Scrapper Blades to match cutting head size. A 38.1 cm (15") scrapper blade would use a 35.5 cm (14") Cutting Head. Razor Blades are faster but a Cutting Head from 20.3 to 35.5 cm (8" to 14") can be used with a Standard Blade. Sharp blades are imperative for re-scraping.

### THIN COATING SET-UP

Slide plate should be set high, 15.25 cm (6") off the floor. Use a Cutting Head from 20.3 to 35.5 cm (8" to 14") with Razor Blades to match cutting head size.

### WORKING OVER CONCRETE

Blade should be bevel up when working over concrete. Pretty much anything over concrete works. Try different set-ups to see which works best. If goods come up difficult, slide plate should be at a low setting, 2.5 cm (1") off the floor. Use a smaller size blade. If goods come up easily, slide plate can be at a high setting and a wider blade can be used.

### WORKING OVER WOOD

A heavy machine cannot be used on wood subfloors or raised panel computer floors. Keep machine light, remove all weights. A weighted machine could break through the floor. Slide plate should be set low, 2.5 cm (1") off the floor. Blades should be as flat of an angle as possible. Use a "shoe blade", Extra Heavy Duty Blade (these blades have a bend to them) or a regular blade, bevel up. When using a regular blade, bending up the corners of the blade will help from the blade digging into the floor. Sometimes a shank blade or a shank blade with a carbide tip will work. The trick on wood floors is to run the blade flat.

### WORKING OVER SOFT SUB-FLOOR

Slide plate should be set low, 2.5 cm (1") off the floor. Blades should be as flat of an angle as possible. Use a "shoe blade", Extra Heavy Duty Blade (these blades have a bend to them) or a regular blade, bevel up. When using a regular blade, bending up the corners of the blade will help from the blade digging into the floor. Sometimes a shank blade or a shank blade with a carbide tip will work.

# Machine Operation

## DITCHING

### CROSS ROOM DITCHING

When removing hard to remove ceramic, Vct or vat, cross-room ditching will help to make the removal easier. Using a blade 5 to 15.25 cm (2" to 6") in width, make ditches 30.5 to 61 cm (1' to 2') apart in the same direction the machine will be removing the goods (See Figure EE). This "relieves" the pressure holding the tiles together. If ditching helps and the goods are coming up easy, try using a wider blade to ditch with.

### CHECKER BOARD DITCHING

To make carpet removal and debris cleanup easier, checker board ditching is very helpful. Using as wide of a self-scoring blade as possible, make ditches 1.2 to 1.8 m (4' to 6') apart crossways from the way the machine will be removing the goods (See Figure FF). Running the machine crossways from the ditches will make smaller pieces of debris to be hauled away. Instead of large gummy rolls of carpet, there are small squares that can be rolled, palletized, put on a dolly or folded with the sticky side in. This makes removing the debris easier and reduces the amount of debris.

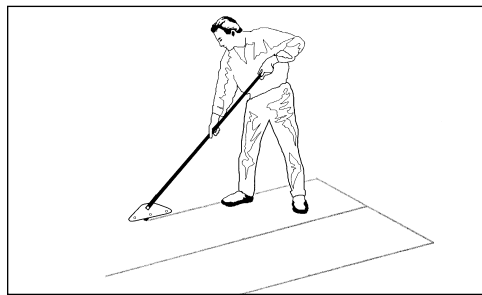
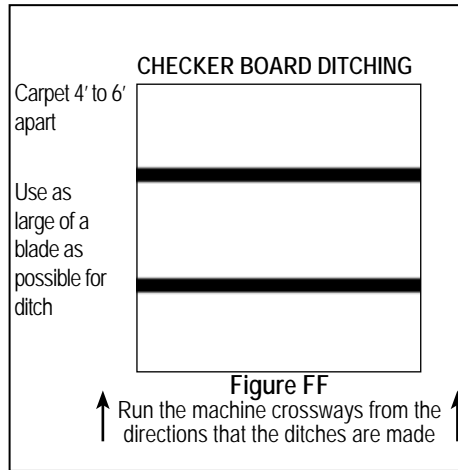
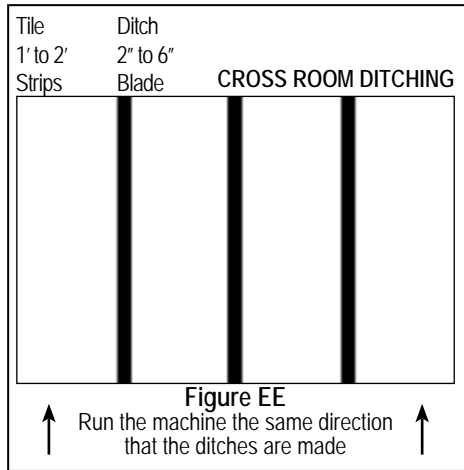

**FIG. GG**

## TYPES OF BLADES

### PREMIUM HIGH TEMPERED BLADES

Works on all glued down carpets, VCT, VAT, rubber tile, cork, re-scraping adhesive, elastomeric coatings. Great for floor accumulations. Ultra high quality spring steel is extra hard for long blade life between sharpening.

### HEAVY DUTY BLADES

Works on VCT, VAT, wood, tile, rubber epoxy, thin-set, elastomeric coatings, scraping, thin set and glued ceramic. A heavy-duty blade that still gives a little flex. Blade sharpening process helps these blades to stay sharper longer.

### EXTRA HEAVY DUTY BLADES

Works on VCT, VAT, wood, tile, thin ceramic, re-scraping thin set, all carpets, cork, elastomeric coatings re-scraping rubber and urethane coatings. Extremely hard, high abrasion alloy for tough tear-up situations. Holds the edge extremely well.

### SHOE BLADES/ANGLE SHANK BLADES

Works well for ceramic, wood, thick epoxy, thin-set, mud set, decorative concrete topping and much more. Blade is mounted at an angle to achieve the optimum shear point for optimum performance. Made from an ultra tough alloy, which is put through special processing to achieve an unbelievable edge holding ability.

### SHOE BLADES/ANGLE SHANK BLADES WITH CARBIDE TIPS

Works well for ceramic, wood, thick epoxy and elastomeric coatings. Carbide tipped for holding a sharp edge for long periods. Nothing else performs like carbide when no other blade will work. Blade is mounted at an angle to achieve the optimum shear point for optimum performance. Made from an ultra tough alloy, which is put through special processing to achieve an unbelievable edge holding ability.

### SELF SCORING BLADES

Works on attached cushion, Unitary or secondary backing, vinyl back, soft to medium PVC, linoleum, carpet tiles, soft cork, Enhancer and Unibond hot melts. Instead of pre-scoring a job, the self scoring blades have "wings" that automatically do the scoring. Blade hardening process makes these blades tough and long lasting.

### RAZOR/SCRAPER BLADES

Used for re-scraping thin epoxies, thin mil coatings like; urethane paint, poured elastomeric coatings up to 60 mil, hard to remove adhesive and much more.

### TILE BOX

Assists for a fast cleanup and collection of tile debris for quick removal. Can be used to remove easy to remove tile. Extremely high abrasion alloy for a long lasting edge. Edge can be re-sharpened.

# Blades

## BLADE SHARPENING

Dull blades greatly reduce cutting ability. Re-sharpen or replace as needed. In use, blades develop a back-bevel (See Figure HH). When re-sharpening, blade will not be truly sharp until all back-bevel is gone.

Note: Thinner blades are easier to sharpen, but they also break easier.

- Always wear gloves and safety glasses.
- Grind blade using a 4" diameter disk with 120 or finer grit. Be careful not to catch disk on edge or corner of blade.
- Pass grinder back and forth along blade edge being careful to hold grinder at proper angle of blade. Grind until sharp.
- Using a good quality fine tooth hand file, use same procedure as above.
- Blades are sharp. Use extreme caution.
- Have plenty of sharp blades on each job so on-the-job blade sharpening is eliminated.
- It is best to resharpen dull blades on proper bench or belt grinder in the shop, so the blades are ready for the next job.

## SELF SCORING BLADE SHARPENING

It is important to keep the "wings" on a self scoring blade sharp (See Figure II). Use a file on the "wing" edge. Sharpen the flat part of the blade, the same way as described above.

## CARBIDE TIPPED BLADE SHARPENING

To sharpen carbide tipped blades, a wheel to grind carbide is necessary, ie: green wheel or diamond wheel.

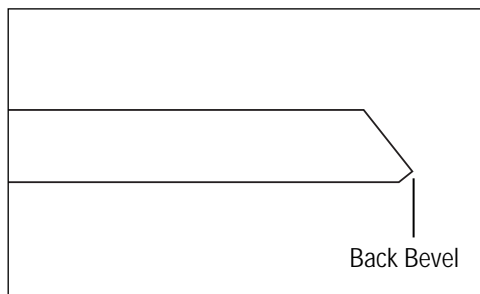

FIG. HH

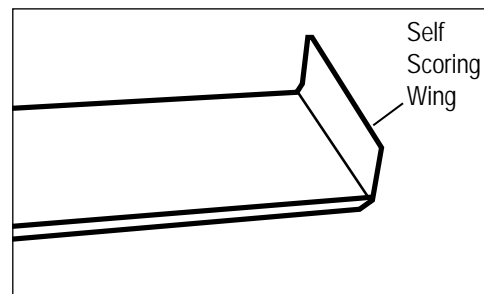

FIG. II

## STANDARD BLADE (FIGURE JJ)

This heavy duty blade is designed to remove soft goods, carpet, and vinyl flooring. Its .062 thickness offers flexibility to maximize the shear point angle.

PART#	DESCRIPTION	THICKNESS (IN.)
1 135	5" X 16" BLADE	.062
2 147	4" X 6" BLADE	.062
3 148	5" X 6" BLADE	.062

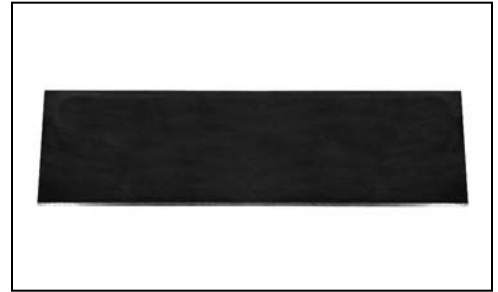

FIG. JJ

## RAZOR/SCRAPER BLADES (FIGURE KK)

These razor sharp blades are designed for super hard thin epoxies, thin mil coatings (like urethane paint), poured elastomeric coatings up to 60 mil and hard to remove adhesives.

PART#	DESCRIPTION	THICKNESS (IN.)
1 363-2	3/4" X 8" RAZOR/SCRAPER BLADE (50/PKG)	.032
2 368-8	7/8" X 8" RAZOR/SCRAPER BLADE (50/PKG)	.045
3 368-12	7/8" X 12" RAZOR/SCRAPER BLADE (50/PKG)	.045
4 368-15	7/8" X 15" RAZOR/SCRAPER BLADE (50/PKG)	.045

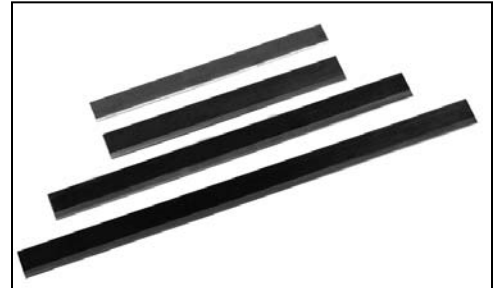

FIG. KK

## SELF-SCORING BLADES (FIGURE LL)

These 90° angled self-scoring wing tipped blades are tough and long lasting. Made from National's proven blade hardening process, they perform up to ten times longer than the competition. They work on attached cushion, unitary or secondary backing, vinyl back, soft to medium PVC, linoleum, carpet tiles, soft cork, enhancer and unbond hot melts.

PART#	DESCRIPTION	THICKNESS (IN.)
1 6258-BU	3" X 12" SELF-SCORING BLADE	.062
2 6259-BU	3" X 14" SELF-SCORING BLADE	.062
3 6260-BD	3" X 6" HEAVY DUTY DITCHING	.094
4 6276-BU	3" X 10" SELF-SCORING BLADE	.094
5 6277-BU	3" X 12" SELF-SCORING BLADE	.094
6 6278-BU	3" X 14" SELF-SCORING BLADE	.094



FIG. LL

## HEAVY DUTY BLADES (FIGURE MM)

This heavy duty blade is flexible and delivers jobsite versatility. Made with National's proven blade hardening process, these blades will stay sharper longer with better overall performance than any other blade on the market. They work on VCT, VAT, wood, tile, rubber, epoxy, elastomeric coatings, scraping thin-set and glued ceramic.

PART#	DESCRIPTION	THICKNESS (IN.)
1 6281	3" X 8" HEAVY DUTY BLADE	.094
2 6282	3" X 14" HEAVY DUTY BLADE	.094
3 6284	3" X 12" HEAVY DUTY BLADE	.094
4 6285	3" X 6" HEAVY DUTY BLADE	.094
5 6286	3" X 10" HEAVY DUTY BLADE	.094



FIG. MM

## EXTRA HEAVY DUTY BLADES (FIGURE NN)

These extremely hard, high abrasion alloy blades are designed for tough tear up situations. VCT, VAT, wood, tile, lighter ceramic, re-scraping thin-set, all carpets, cork, elastomeric coatings, re-scraping rubber and urethane coatings. They hold all edges extremely well.

PART#	DESCRIPTION	THICKNESS (IN.)
1 6290	3" X 6" EXTRA HEAVY DUTY BLADE	.187
2 6291	3" X 8" EXTRA HEAVY DUTY BLADE	.187
3 6292	3" X 12" EXTRA HEAVY DUTY BLADE	.187
4 6293	3" X 14" EXTRA HEAVY DUTY BLADE	.187
5 6294	3" X 27" EXTRA HEAVY DUTY BLADE	.187

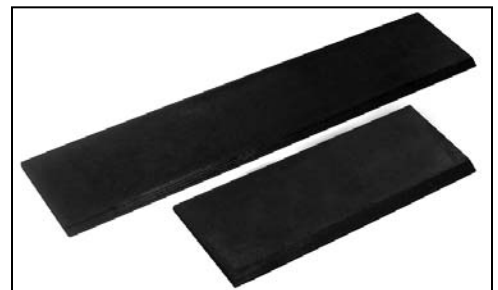

FIG. NN

# Blades



FIG. OO

## PREMIUM HIGH TEMPERED BLADES (FIGURE OO)

These ultra-high quality spring steel blades are extra hard; ensuring long blade life between sharpenings. They work on all glued down carpets, VCT, VAT, rubber tile, cork, re-scraping adhesive and elastomeric coatings. Great for floor accumulations!

PART#	DESCRIPTION	THICKNESS (IN.)
1 7050-200	3" X 6" PREMIUM HIGH TEMPERED BLADE	.062
2 7050-201	3" X 8" PREMIUM HIGH TEMPERED BLADE	.062
3 7050-202	3" X 10" PREMIUM HIGH TEMPERED BLADE	.062
4 7050-203	3" X 12" PREMIUM HIGH TEMPERED BLADE	.062
5 7050-204	3" X 14" PREMIUM HIGH TEMPERED BLADE	.062
6 7050-205	3" X 27" PREMIUM HIGH TEMPERED BLADE.	.062



FIG. PP

## STRAIGHT SHANK BLADES (FIGURE PP)

Works well for ceramic, wood and thick epoxy. The ultimate for the toughest removals. Made from an ultra tough alloy, which is put through special processing to give these blades unbelievable edge holding ability for ceramic epoxy, thin-set, mud set, decorative concrete toppings and much more.

PART#	DESCRIPTION	THICKNESS (IN.)
1 7070-2	4" X 2" STRAIGHT SHANK BLADE	.500
2 7070-3	4" X 3" STRAIGHT SHANK BLADE	.500
3 7070-4	4" X 4" STRAIGHT SHANK BLADE	.500
4 7070-6	4" X 6" STRAIGHT SHANK BLADE	.500



FIG. QQ

## ANGLE SHANK BLADES (FIGURE QQ)

Works well for ceramic and thick epoxy. The same application as the #7070 blades, but is mounted at an angle to achieve the optimum shear point for optimum performance.

PART#	DESCRIPTION	THICKNESS (IN.)
1 7071-2	4" X 2" ANGLE SHANK BLADE	.500
2 7071-3	4" X 3" ANGLE SHANK BLADE	.500
3 7071-4	4" X 4" ANGLE SHANK BLADE	.500
4 7071-6	4" X 6" ANGLE SHANK BLADE	.500



FIG. RR

## STRAIGHT SHANK W/ CARBIDE TIP (FIGURE RR)

These shanks work with a similar application variety as the 7070 blades. These carbide tipped shanks hold a sharp edge for longer durability. These blades perform when all others fail. Perfect for elastomeric coatings!

PART#	DESCRIPTION	THICKNESS (IN.)
1 7072-2	4" X 2" STRAIGHT SHANK W/ CARBIDE TIP	.500
2 7072-3	4" X 3" STRAIGHT SHANK W/ CARBIDE TIP	.500
3 7072-4	4" X 4" STRAIGHT SHANK W/ CARBIDE TIP	.500
4 7072-6	4" X 6" STRAIGHT SHANK W/ CARBIDE TIP	.500



FIG. SS

## TAPERED CUTTING HEAD SHANKS (FIGURE SS)

The longer taper works great on tough wood floors (glued & nailed). The long length allows the blade to easily slide under tough material. Works well on most ceramics and VCT.

PART#	DESCRIPTION	THICKNESS (IN.)
1 7075-8	2" X 8" TAPERED CUTTING HEAD SHANK	.300
2 7075-11	2" X 11" TAPERED CUTTING HEAD SHANK	.300
3 7077-8	3.5" X 8" TAPERED CUTTING HEAD SHANK	.300
4 7077-11	3.5" X 11" TAPERED CUTTING HEAD SHANK	.300

## TAPERED CUTTING HEAD SHANKS (FIGURE TT)

The longer taper works great on tough wood floors (glued & nailed). The long length allows the blade to easily slide under tough materials. They work through most ceramics and VCT.

	<b>PART#</b>	<b>DESCRIPTION</b>	<b>THICKNESS (IN.)</b>
1	7076-8	2" X 8" TAPERED W/ CARBIDE TIP	.300
2	7076-11	2" X 11" TAPERED W/ CARBIDE TIP	.300
3	7078-8	3.5" X 8" TAPERED W/ CARBIDE TIP	.300
4	7078-11	3.5" X 11" TAPERED W/ CARBIDE TIP	.300



FIG. TT

## ULTRA HEAVY DUTY CERAMIC EPOXY ANGLE SHANKS W/ CARBIDE TIPS (FIGURE UU)

Designed for ceramic removal and thin-set rescraping. 1/2" of carbide. The extra carbide allows for maximum resharpening. Strong enough to work on machines up to 3500 lbs.

	<b>PART#</b>	<b>DESCRIPTION</b>	<b>THICKNESS (IN.)</b>
1	7079-2	2" X 6" ULTRA HD CERAMIC EPOXY BLADE	.500
2	7079-4	4" X 6" ULTRA HD CERAMIC EPOXY BLADE	.500
3	7079-6	6" X 6" ULTRA HD CERAMIC EPOXY BLADE	.500



FIG. UU

## INCREASED ANGLE BLADES (FIGURE VV)

These blades are mainly used for VCT, but can be used on most other applications. They supply a greater angle when needed. Prevents machine from jumping off material. They contribute to keeping the machine steady and reduce jumping.

	<b>PART#</b>	<b>DESCRIPTION</b>	<b>THICKNESS (IN.)</b>
1	7081	3" X 10" INCREASED ANGLE BLADE	.062
2	7083	3" X 8" INCREASED ANGLE BLADE	.062

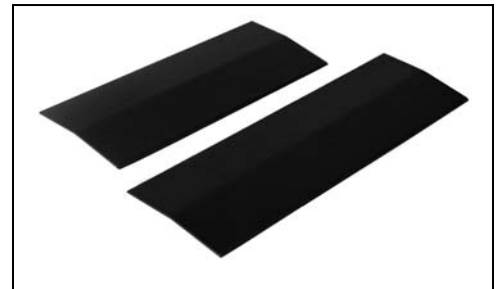
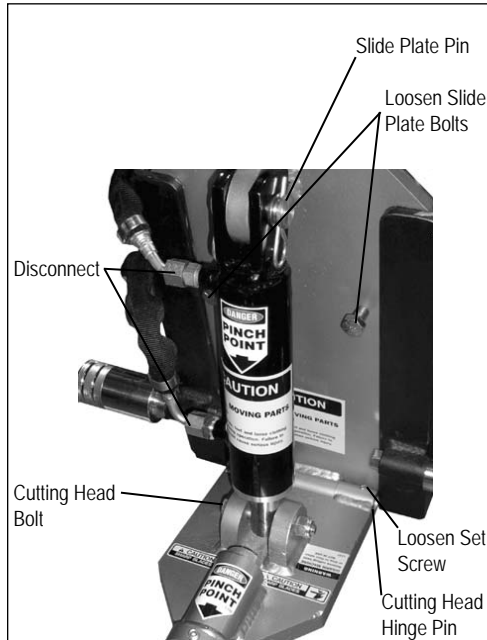

FIG. VV

# Machine Maintenance



**FIG. WW**

**Take Caution:** slide plate will drop to the floor when slide plate securing bolts are disengaged. Keep hands and feet out from underneath slide plate, failure to do so could cause severe bodily injury.

## SLIDE PLATE (SEE FIGURE WW)

To Remove Slide Plate

1. Disconnect machine from power.
2. Remove slide plate pin. Remove cutting head bolt. Remove cylinder from slide plate. Remove slide plate.

or

1. Disconnect machine from power.
2. Unplug hydraulic lines from cylinder. A small amount of oil leak out of lines. Cap lines or bleed into a container. Wipe up spillage immediately.
3. With lines removed, loosen slide plate securing bolts. Hold slide plate at the top of the cylinder. Take Caution: slide plate will drop to the floor when slide plate securing bolts are disengaged. Keep hands and feet out from underneath slide plate.
4. Remove slide plate, cylinder and lower cutting head support.

## LOWER CUTTING HEAD SUPPORT

To Remove Lower Cutting Head Support

1. Lower slide plate so cutting head hinge pin is below machine bottom. Retighten.
2. Loosen both cutting head pin set screws at the base of the lower cutting head support (hinge area).
3. Drive cutting head pin out using a punch and hammer.
4. Remove cylinder securing hex head bolt.

## LEAK MAINTENANCE

All fittings on this machine are O-ring style.

1. Disconnect machine from power.
2. If a leak is detected, tighten fitting with the proper wrench size. DO NOT over tighten. Over tightening could damage O-rings.
3. If a leak still persists, remove fitting and replace O-ring.

# Machine Maintenance

## SIDE AND REAR PANELS

To Remove A Panel

1. Using proper wrench size, remove hood.
2. Remove desired side or rear panel.

## OIL LEVEL

To Check Oil Level

1. Remove oil level plug (See Figure XX). Plug is either on the front or the rear of the tank. If it is on the rear of the tank, the hood will need to be removed to access the plug.
2. Oil should be visual at the bottom of the oil level plug hole. If it is over filled, oil will run out of the plug hole until it is at the proper level.
3. Reinsert plug.

## OIL CHANGE OUT

1. Disconnect machine from power.
2. Drain fluid by removing the drain plug from side of tank (See Figure XX). Take Caution: this unit contains twelve gallons of fluid. Make sure you have the proper amount of containers to catch fluid.
3. Replace drain plug.
4. Remove filler plug (See Figure XX).
5. Add oil into the filler plug hole until visual at the bottom of the oil level plug hole.

## WHEEL MOTOR CHANGE OUT

1. Disconnect machine from power.
2. Block up machine to remove wheel. See wheel changing on page 30.
3. Remove wheel.
4. Remove oil lines from wheel motor. A small amount of oil will run out of the lines. Drain into a container. Wipe up spills immediately.
5. Remove four ½" wheel motor securing nuts.
6. Pull out on wheel motor to remove.

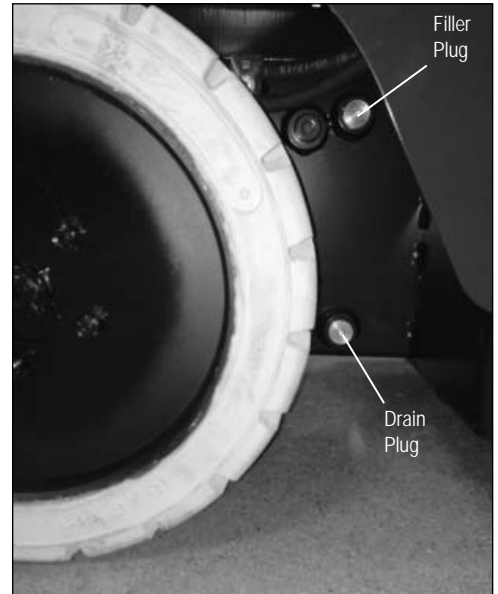

**FIG. XX**

# Machine Maintenance

---

## HOSE CHANGE OUT

To Remove or Change A Hose

1. Disconnect machine from power.
2. Remove hood.
3. Using proper wrench size, remove hose from fitting.
4. When replacing, make sure O-ring is properly seated on hose fitting.

## FOOT PEG

To Remove or Replace Foot Peg

1. Insert a socket wrench into foot peg and secure bolt head.
2. Remove nut and washer.
3. Remove bolt and foot peg.
4. Replace foot peg before operating machine. DO NOT use machine without foot pegs.

## PUMP CHANGE OUT

1. Disconnect machine from power.
2. Remove hood.
3. Remove lines from either side of pump. Have a container ready to catch leakage from lines.
4. Remove two 5/16" pump securing bolts.
5. Remove pump by pulling pump straight out from pump motor.

## VALVE CHANGE OUT

1. Disconnect machine from power.
2. Remove hood.
3. Remove hoses from valve body. Have a container ready to catch leakage from lines.
4. Take notice of angle of valve fittings.
5. Remove two 1/4" bolts securing valve body.

## MOTOR CHANGE OUT

1. Disconnect machine from power.
2. Remove hood.
3. Remove four 9/16" bolts securing pump bracket and pump to motor.
4. Pull pump and bracket straight out from motor. It is not necessary to unhook pump hoses.
5. Remove motor.

# Machine Maintenance

## MOTOR OVERLOAD SWITCH

Motor is equipped with a thermal overload switch. Switch will trip if motor runs too hot.

1. Let motor cool off.
2. Depress red button on end of motor junction box located on motor under the hood. Switch presses hard.

## ELECTRICAL BOX

To Replace Electrical Box

1. Disconnect machine from power.
2. Remove hood.
3. Disconnect back-up beeper switch wiring.
4. Disconnect seat switch wires.
5. Remove two ¼" electrical box securing nuts.
6. Remove electrical box.

## HYDRAULIC CYLINDER CHANGE OUT

1. Disconnect machine from power.
2. Disconnect cylinder lines. Have a container ready to catch oil from lines.
3. Remove cylinder securing hexhead bolt from lower cutting head support.
4. Remove clips and pin from cylinder and slide plate.
5. Remove cylinder upper pin.
6. Remove cylinder.

## ELECTRICAL CORD

If the supply cord is damaged, it must be replaced by the manufacturer or its service agent or a similarly qualified person in order to avoid a hazard.

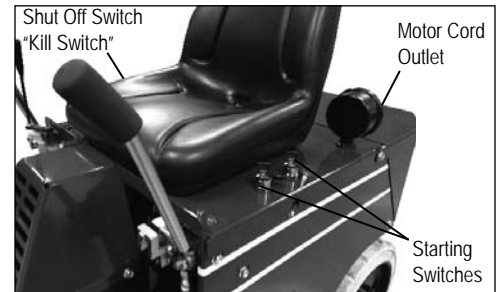
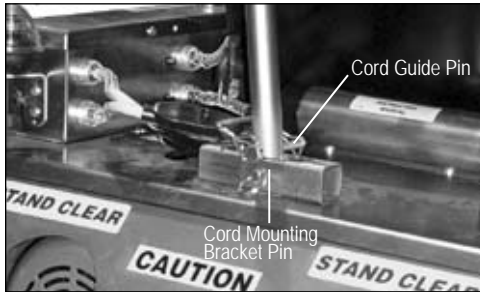

FIG. YY

# Machine Maintenance



**FIG. ZZ**



**FIG. AB**

## CORD GUIDE

To Adjust Cord Guide, rotate to either side.

To stand straight up.

1. Remove cord guide pin.
2. Adjust cord guide straight up position.
3. Reinsert cord guide pin.

## TO REMOVE CORD GUIDE

1. Remove cord mounting bracket pin (See Figure ZZ).
2. Remove cord guide.

## TO REMOVE CORD GUIDE BRACKET

1. Remove cord guide as previously described.
2. Remove two cord guide securing nuts from underneath the hood.
3. Remove two cord guide securing screw.
4. Remove bracket.

## WHEEL CHANGING (FIGURE AB)

1. Jack machine up by pushing the cylinder lift forward to lower and adjust the angle of the cutting head to raise machine.
2. Place blocks under Forklift Cups on the side of the machine that wheel is being changed.
3. Take Caution: Make sure machine is supported properly or serious injury could occur.
4. Let cylinder down resting machine on blocks allowing rear wheel to be lifted off the floor.
5. Remove five 1/2" lug nuts with an extended arm wrench, remove wheel.
6. Replace wheel.
7. Replace five lug nuts and tighten, making sure lug nuts are very tight.
8. Raise cylinder to raise machine off of blocks. Remove blocks and lower machine.
9. Repeat to other side if necessary.

## CHANGING FILTER (FILTER SHOULD BE REPLACED YEARLY)

1. Place pan or rag below filter to catch excess hydraulic fluid.
2. Unscrew filter by hand or with wrench.
3. Use excess hydraulic fluid to lubricate seal on new filter.
4. Hand tighten replacement filter.

**Do not over tighten filter, should only be hand tightened.**

# Machine Maintenance

## CASTER MAINTENANCE

1. Keep clean and free of debris, make sure it can move freely.
2. Give a shot of grease in grease zerc on caster every six months to keep moving freely.
3. To remove caster, machine will need to be raised. Push the cylinder lift lever forward to lower and adjust the angle of the cutting head to jack up the machine (See Figure AI). Block up machine (See Figure AJ). Remove four bolts, pull caster off, clean/replace as needed.
4. Replace caster.
5. Replace and firmly tighten the four bolts.
6. Lower the machine.
7. Push the cylinder lift lever forward to lower and adjust the angle of the cutting head to jack up the machine (See Figure AC).



**FIG. AC**

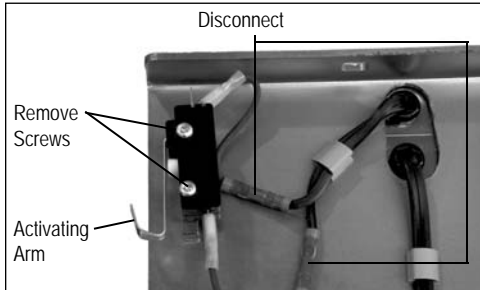

**FIG. AD**

# Machine Maintenance



**FIG. AE**



**FIG. AF**

## BACK UP BEEPER AND LIGHT

To replace bulb (Figure AE):

- Pop off cover with a screwdriver.
- Wearing gloves or using a cloth, replace bulb. Do Not touch bulb. Do not get the oils from your hand on the bulb.
- Snap cover back on into position.
- To replace back-up beeper switch: (Figure AF).
- Remove two button hexhead screws on each side of the hood.
- Lift hood off and disconnect seat switch and back-up beeper switch.
- Remove both screws from the back-up beeper switch.
- Remove and replace switch.
- Re-insert both screws into switch. Firmly tighten.
- Activating arm may need to be adjusted. Beeper should sound when valve handle has 1/3 movement. If it does not sound with 1/3 movement or sounds too quickly, adjust (bend) activating arm with a needle nose plier.
- Reconnect back-up beeper and seat switch wires.
- Replace hood and screws.



**WARNING:** DO NOT ALTER A SWITCH. DO NOT DEFEAT A SAFETY DEVICE.



**WARNING:** THE BACK UP BEEPER AND LIGHT ARE ON THE MACHINE FOR SAFETY. IT IS IMPORTANT TO KEEP IT IN GOOD WORKING CONDITION. FAILURE TO DO SO COULD CAUSE BODILY INJURY.

# Machine Maintenance

## SEAT REPLACEMENT

1. Remove two button hexhead screws on each side of the hood (4 times).
2. Lift hood off.
3. Disconnect seat switch and back-up beeper switch (See Figure AI).
4. Remove four 5/16 button hexhead screws (See Figure AI).
5. Remove seat.
6. To replace seat, set seat on top of hood.
7. Replace the four 5/16 button hexhead screws from underneath the hood.
8. Firmly tighten.
9. Reconnect back-up beeper and seat switch wires.
10. Replace hood and screws.

## SEAT SAFETY SWITCH

The seat safety switch is mounted under the center portion of the seat. This switch is designed as an emergency shut off. If you are not sitting down on the seat, the machine will shut off.

1. Remove two button hexhead screws on each side of the hood (4 times).
2. Lift hood off.
3. Disconnect seat switch and back-up beeper switch (See Figure AC).
4. Push down on three tabs (See Figure AH).
5. Turn switch assembly counter-clockwise and remove switch (See Figure AI).
6. Replace switch and turn clockwise to secure.
7. Reconnect seat switch and back-up beeper switch.
8. Replace hood and screws.

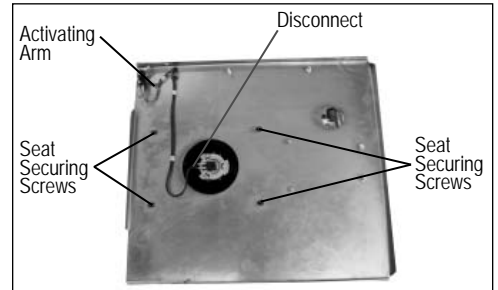

FIG. AG

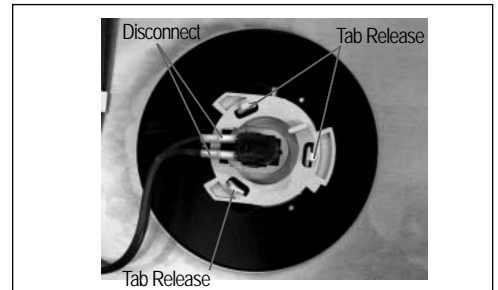

FIG. AH

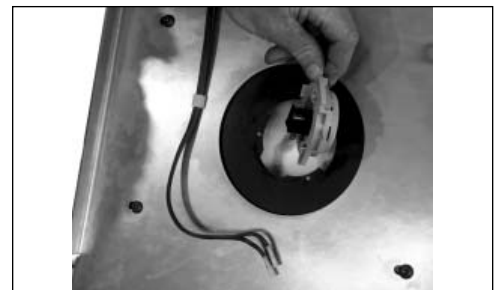

FIG. AI



**WARNING:** DO NOT ALTER A SWITCH. DO NOT DEFEAT A SAFETY DEVICE.

# Machine Maintenance



**FIG. AJ**

## #5200-258 DEBRIS DEFLECTOR MOUNTING INSTRUCTIONS (SEE FIGURE AJ)

- Insert and secure a cutting head, making sure cutting head is all the way in.
- If there are holes on your lower cutting head support, place debris deflector under the lower cutting head support and bolt in place.
- If there are not holes on the lower cutting head support, place debris deflector on the lower cutting head support, measuring a 2.5 cm (1") clearance between the cutting head and the front of the debris deflector. This clearance will reduce a "pinch point".
- Secure with C-clamps.
- Mark the holes from the debris deflector on the lower cutting head support.
- Either drill a 1/2" hole on each mark and secure debris deflector with a bolt and lock nut OR drill a 27/64" hole and tap 1/2-13.
- Firmly secure debris deflector under the cutting head.

# Complete Parts List

PART#	DESCRIPTION	QTY	PART#	DESCRIPTION	QTY		
1	70358	HOSE, 3/4", RETURN LINE TO FILTER	1	61	400133	MOTOR, WHEEL, HYDRAULIC, 10MM	2
2	70359	HOSE, 3/4", RETURN LINE TO TANK	1	62	400327	HANDLE RUBBER COVER	2
3	70602	INSTRUCTION MANUAL TUBE	1	63	401429	PIN, LOWER CUTTING HEAD SUPPORT	1
4	70602	INSTRUCTION MANUAL TUBE	1	64	401438	PLUG, MALE EU1-16P (NOT SHOWN)	1
5	70603	CAP, INSTRUCTION TUBE	1	65	401567	SLIDE PLATE	1
6	70603	INSTRUCTION TUBE CAP	1	66	401568	LOWER CUTTING HEAD SUPPORT	1
7	70652	FITTING	2	67	401876	SSS, 3/8-24 X .25, BLACK OXIDE	2
8	70925	SPLINE SHAFT PUMP	2	68	5110-111	SEAT	1
9	72366	MOTOR 115/230 VOLT, 1-1/2 HP, 1725 RPM	1	69	5110-114-2	WHEEL MOTOR FITTING	4
10	72804	STRAIN RELIEF, STRAIGHT, 1/2"	3	70	5110-115	SINGLE SPOOL CONTROL	1
11	72816	3/8 90° PUMP FITTING (NOT SHOWN)	1	71	5110-116	DOUBLE SPOOL CONTROL	1
12	73008	1/4-20 NYLON LOCK NUT	4	72	5110-117	WHEEL HUB	2
13	73020	1/4-20 X 5/8 WIZLOCK BOLT	3	73	5110-117-2	HUB NUT	2
14	73021	1/4-20 X 2 1/4 HEXHEAD BOLT	4	74	5110-156	OIL LEVEL PLUG	2
15	73027	BOLT, FLANGE 1/4-20X3/4	4	75	5110-157	DRAIN/FILL PLUG	2
16	73047	1/4 X 1 WOODRUFF KEY	1	76	5110-168	MOTOR POWER CORD	1
17	73105	1/8 X 2 COTTER PIN	2	77	5110-174	SINGLE CAPACITOR 125 VAC (NOT SHOWN)	1
18	73130	1/8 X 1/8 X 3/4 PUMP KEY (NOT SHOWN)	2	78	5110-175	SINGLE CAPACITOR COVER	1
19	73201	3/8-16 X 1 HEXHEAD BOLT	8	79	5110-176A	OVERLOAD SWITCH	1
20	73202	3/8 INTERNAL LOCK WASHER	6	80	5110-177	HUBBLE TWIST LOCK MALE PLUG	1
21	73203	3/8 FLAT WASHER	8	81	5110-178	STRAIN RELIEF	1
22	73204	3/8 SPLIT LOCK WASHER	8	82	5110-180	FOOT PEG	1
23	73204	3/8 SPLIT LOCK WASHER	2	83	5110-180	FOOT PEG	2
24	73207	3/8-16 NYLON LOCK NUT	2	84	5110-185	MOTOR FAN COVER	1
25	73207	3/8-16 NYLON LOCK NUT	8	85	5110-186	MOTOR FAN (NOT SHOWN)	1
26	73207	3/8-16 NYLON LOCK NUT	2	86	5110-187	CAPACITOR 240 VAC (NOT SHOWN)	2
27	73208	3/8-16 X 1 1/2 HEXHEAD CAP SCREW	2	87	5110-188	DOUBLE CAPACITOR COVER	1
28	73213	SCREW, BUTTON HEAD SOCKET CAP	8	88	5110-200	MOTOR MOUNT	2
29	73213	3/8-16 X 3/4 BUTTON HEAD CAP SCREW	3	89	5110-207	SEAT SAFETY SWITCH	1
30	73227	3/8-24 X 1 SET SCREW	3	90	5110-215	GUIDE, EXTENSION CORD	1
31	73235	3/8-24 JAMB NUT	3	91	5110-215	CORD GUIDE	1
32	73236	3/8-16 X 1 HEXHEAD BOLT	2	92	5110-216	CORD GUIDE BRACKET	1
33	73236	3/8-16 X 1 HEXHEAD BOLT	8	93	5110-216-3	3/8-16 X 1 HEXHEAD BOLT	2
34	73240	3/8-16 CORD GUIDE SECURING T-BOLT	1	94	5110-216-4	3/8-16 NYLON LOCK NUT	2
35	73302	5/16 FLAT WASHER	4	95	5110-218	BACK-UP BEEPER SWITCH	1
36	73303	5/16 SPLIT LOCK WASHER	4	96	5110-219	STRAIGHT VALVE FITTING	2
37	73307	5/16-18 X 1 HEXHEAD BOLT	4	97	5110-225	RELAY, 240V	2
38	73308	5/16-18 X 3/4 BUTTON HEAD CAP SCREW	2	98	5110-230	RECTIFIER, TRANSFORM	1
39	73308	5/16-18 X 3/4 BUTTON HEAD SOCKET CAP SCREW	2	99	5110-234	COUPLER, RELIEF VALVE	1
40	73320	5/16-18 X 2 SOCKET HEAD CAP SCREW	1	100	5110-234-1	PIPE, RELIEF VALVE	1
41	73321	5/16-18 X 3 1/2 SOCKET HEAD CAP SCREW	1	101	5110-237	FILTER SCREEN	1
42	73322	5/16 NYLON LOCK NUT	2	102	5110-250	CYLINDER	1
43	73324	5/16-18 X 3 3/4 SOCKET HEAD CAP SCREW	1	103	5110-250-3	CYLINDER SEAL KIT REPLACEMENT	1
44	73402	1/2-13 NYLON LOCK NUT	1	104	5110-251	CYLINDER CONNECTING ROD	1
45	73406	BOLT, HEX HEAD CAP 1/2-13X1-1/4	1	105	5110-261-1	WHEEL MOTOR HOSE CLAMP ASSEMBLY	2
46	73406	1/2-13 X 1 1/4 HEXHEAD BOLT	1	106	5110-261-1	WHEEL MOTOR HOSE CLAMP ASSEMBLY	2
47	73427	BOLT, HEXHEAD CAP 1/2-13X1-1/2	4	107	5110-264	45° VALVE FITTING	2
48	73430	1/2-20 NYLON LOCK NUT	10	108	5110-267	HOSE, CYLINDER	1
49	73504	STRAIN RELIEF, STRAIGHT, 3/4"	1	109	5110-268	STRAIGHT VALVE FITTING	2
50	73536	CYLINDER CLIP	2	110	5110-268	FITTING, VALVE STRAIGHT (NOT SHOWN)	2
51	74425	10/32 KEPS NUT	2	111	5110-270	MOTION CONTROL LEVER	2
52	74428	10/32 FENDER WASHER (NOT SHOWN)	2	112	5110-270-2	LEVER JAMB NUT 5/16	2
53	74501	#6 FLAT WASHER	2	113	5110-271	LEVER BRACKET	1
54	74510	6-32 X 3/8 PANHEAD SCREW	2	114	5110-271	LEVER BRACKET	3
55	74513	6-32 X 3/4 PANHEAD SCREW	2	115	5110-272	CYLINDER LIFT LEVER ONLY	1
56	74854	WEIGHT, POCKET, CAST, RIDE ON	5	116	5110-272	CYLINDER LIFT LEVER ONLY	1
57	74854	FRONT WEIGHT INDIVIDUAL	1	117	5110-301	BACKUP LIGHT ASSEMBLY	1
58	80058	DIPSTICK	1	118	5110-404	REAR WEIGHT (NOT SHOWN)	1
59	400099	HOSE, SUCTION, 1/2" X 20" W/F	2	119	5110-404	REAR WEIGHT	1
60	400132	1/2-13 X 3 1/2 HEXHEAD BOLT	1	120	5110-405	18" WHEEL RIM & TIRE	2

# Complete Parts List

PART#	DESCRIPTION	QTY	PART#	DESCRIPTION	QTY
121	5110-6D	2	144	5700-66	1
122	5200-118-1	1	145	5700-67	1
123	5200-120-1	1	146	5700-70	1
124	5200-194	1	147	5700-71	1
125	5200-194A	2	148	5700-77	2
126	5200-261	4	149	5700-77	1
127	5200-261	4	150	5700-88	1
128	5200-262	2	151	6280-168B	1
129	5200-30-SV	1	152	L08-1	2
130	5200QL-11-LH-W	1	153	L106	2
131	5200QL-11-RH-W	1	154	L106	1
132	5200QL-13	1	155	L137	2
133	5200QL-14	1	156	L142	1
134	5200QL-25-SV	1	157	L155	1
135	5200QL-26-SV	1	158	L165	1
136	5200QL-28-SV	1	159	L223	1
137	5200QL-42-SV	1	160	L33B	1
138	5600-21	1	161	L33C	1
139	5600-22	1	162	L37	2
140	5600-58	1	163	L38	2
141	5700-54	2	164	L66	1
142	5700-64	1	165	L95F	2
143	5700-65	1	166	L98	1

# Parts List and Diagrams

## EXTERNAL PARTS



PART#	DESCRIPTION	QTY	PART#	DESCRIPTION	QTY
1	5200QL-42-SV COVER, HINGED TOP, SILVER VEIN	1	9	5110-215 GUIDE, EXTENSION CORD	1
2	5110-111 SEAT	1	10	74854 WEIGHT, POCKET, CAST, RIDE ON	5
3	5200QL-26-SV PANEL, LEFT, SILVER VEIN	1	11	5110-404 REAR WEIGHT (NOT SHOWN)	1
4	5200QL-25-SV PANEL, RIGHT, SILVER VEIN (OPP. SIDE)	1	12	73406 BOLT, HEX HEAD CAP 1/2-13X1-1/4	1
5	5200QL-28-SV COVER, BATTERY, SILVER VEIN	1	13	73213 SCREW, BUTTON HEAD SOCKET CAP	8
6	70602 INSTRUCTION MANUAL TUBE	1	14	5110-301 BACKUP LIGHT ASSEMBLY	1
7	70603 CAP, INSTRUCTION TUBE	1	15	5200-30-SV DOGHOUSE BASE, ASSEMBLY	1
8	5110-180 FOOT PEG	1			

# Parts List and Diagrams

## ELECTRICAL BOX PARTS

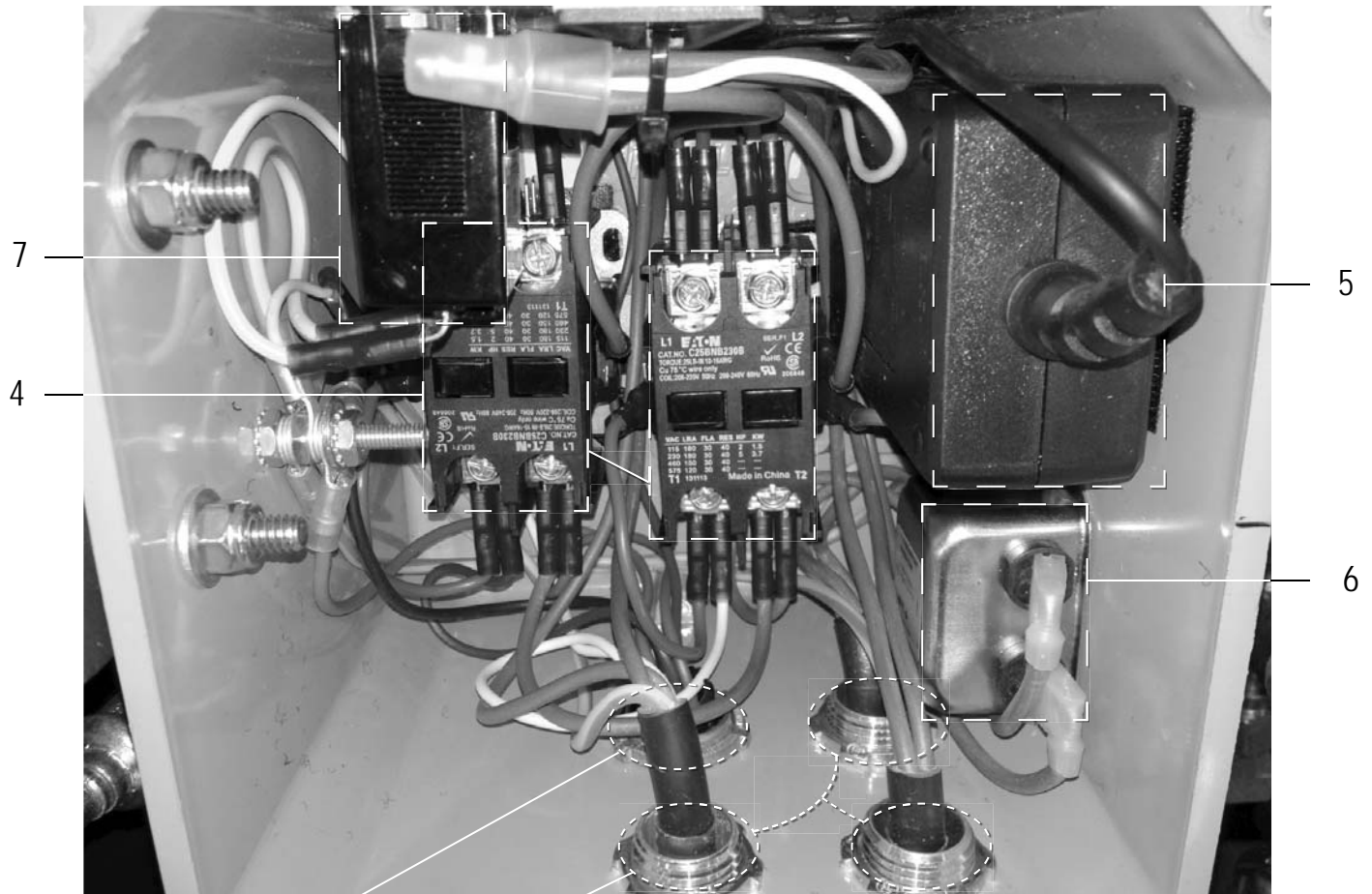

PART#	DESCRIPTION	QTY	PART#	DESCRIPTION	QTY
1	5200-118-1	1	5	5110-230	1
2	72804	3	6	6280-168B	1
3	73504	1	7	5700-88	1
4	5110-225	2			

# Parts List and Diagrams

## SWITCH & BACK-UP BEEPER PARTS

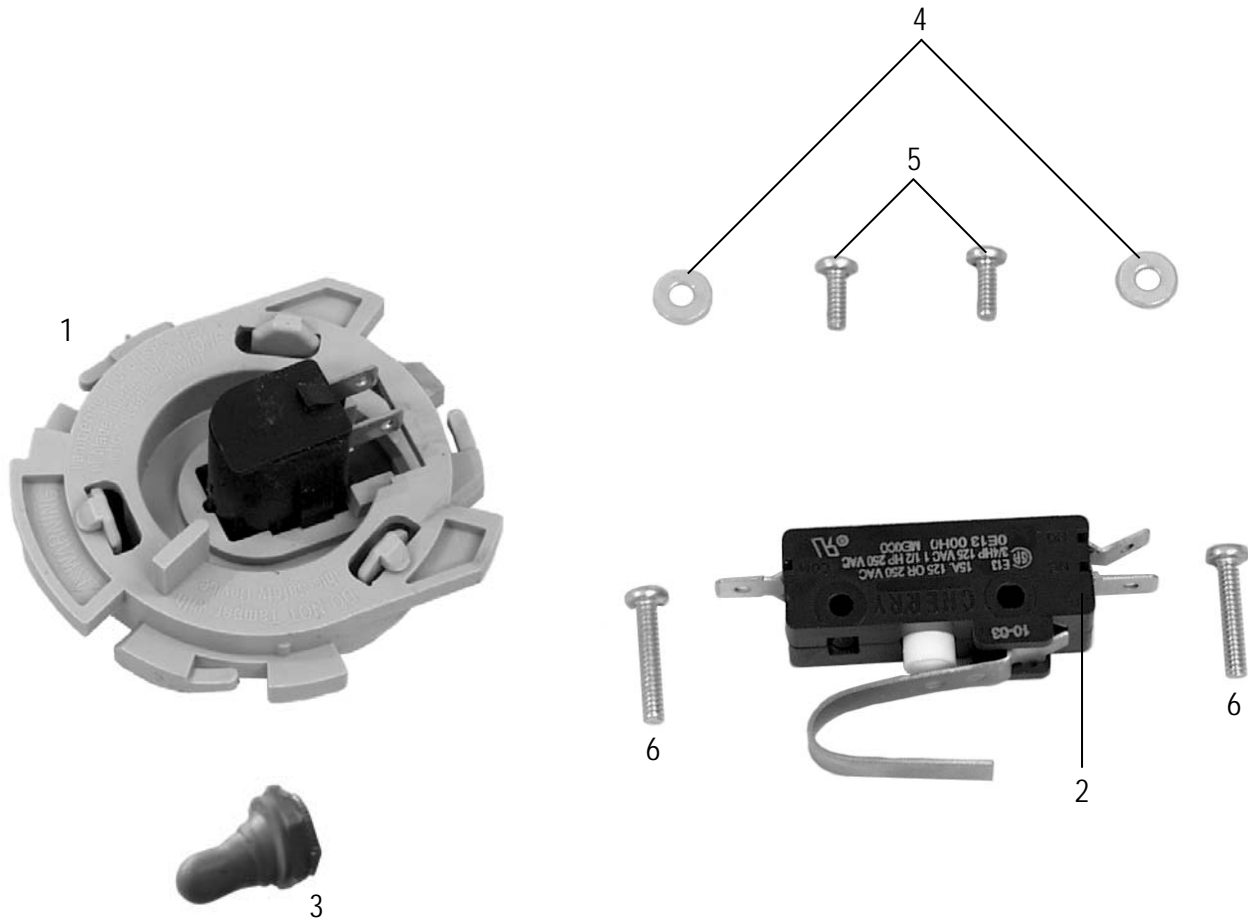

PART#	DESCRIPTION	QTY	PART#	DESCRIPTION	QTY
1	5110-207 SEAT SAFETY SWITCH	1	4	74501 #6 FLAT WASHER	2
2	5110-218 BACK-UP BEEPER SWITCH	1	5	74510 6-32 X 3/8 PANHEAD SCREW	2
3	5200-120-1 RUBBER BOOT ONLY	1	6	74513 6-32 X 3/4 PANHEAD SCREW	2

# Parts List and Diagrams

## INSTRUCTION TUBE & CORD GUIDE PARTS

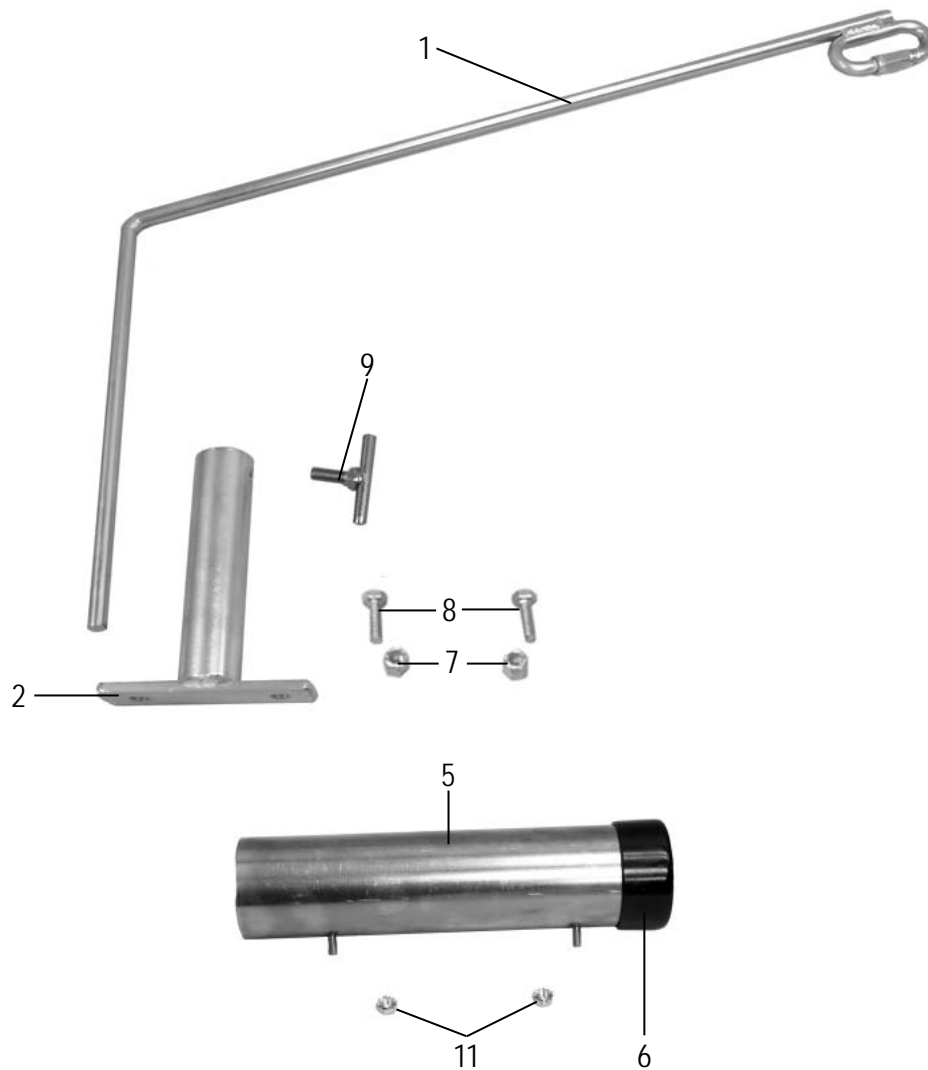

PART#	DESCRIPTION	QTY	PART#	DESCRIPTION	QTY		
1	5110-215	CORD GUIDE	1	7	73207	3/8-16 NYLON LOCK NUT	2
2	5110-216	CORD GUIDE BRACKET	1	8	73236	3/8-16 X 1 HEXHEAD BOLT	2
3	5110-216-3	3/8-16 X 1 HEXHEAD BOLT	2	9	73240	3/8-16 CORD GUIDE SECURING T-BOLT	1
4	5110-216-4	3/8-16 NYLON LOCK NUT	2	10	74428	10/32 FENDER WASHER (NOT SHOWN)	2
5	70602	INSTRUCTION MANUAL TUBE	1	11	74425	10/32 KEPS NUT	2
6	70603	INSTRUCTION TUBE CAP	1				

# Parts List and Diagrams

## MOTOR PARTS

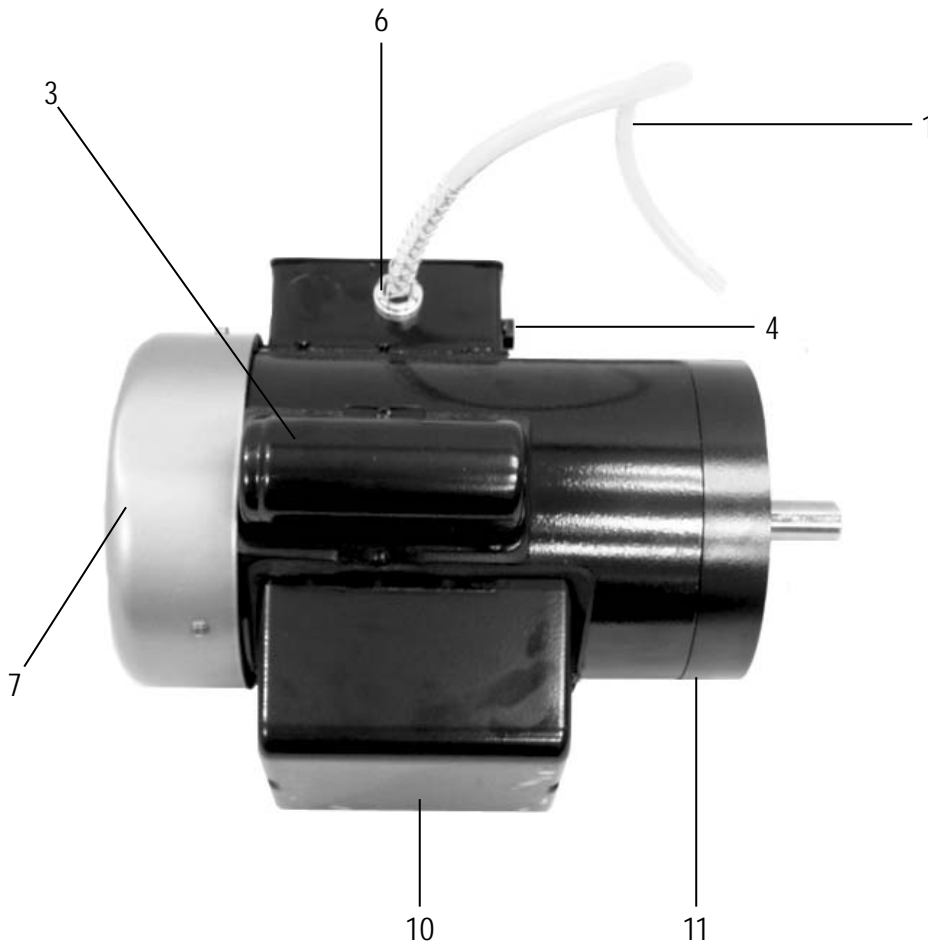

PART#	DESCRIPTION	QTY	PART#	DESCRIPTION	QTY		
1	5110-168	MOTOR POWER CORD	1	7	5110-185	MOTOR FAN COVER	1
2	5110-174	SINGLE CAPACITOR 125 VAC (NOT SHOWN)	1	8	5110-186	MOTOR FAN (NOT SHOWN)	1
3	5110-175	SINGLE CAPACITOR COVER	1	9	5110-187	CAPACITOR 240 VAC (NOT SHOWN)	2
4	5110-176A	OVERLOAD SWITCH	1	10	5110-188	DOUBLE CAPACITOR COVER	1
5	5110-177	HUBBLE TWIST LOCK MALE PLUG	1	11	72366	MOTOR 115/230 VOLT, 1-1/2 HP, 1725 RPM	1
6	5110-178	STRAIN RELIEF	1	12	401438	PLUG, MALE EU1-16P (NOT SHOWN)	1

# Parts List and Diagrams

## PUMP PARTS

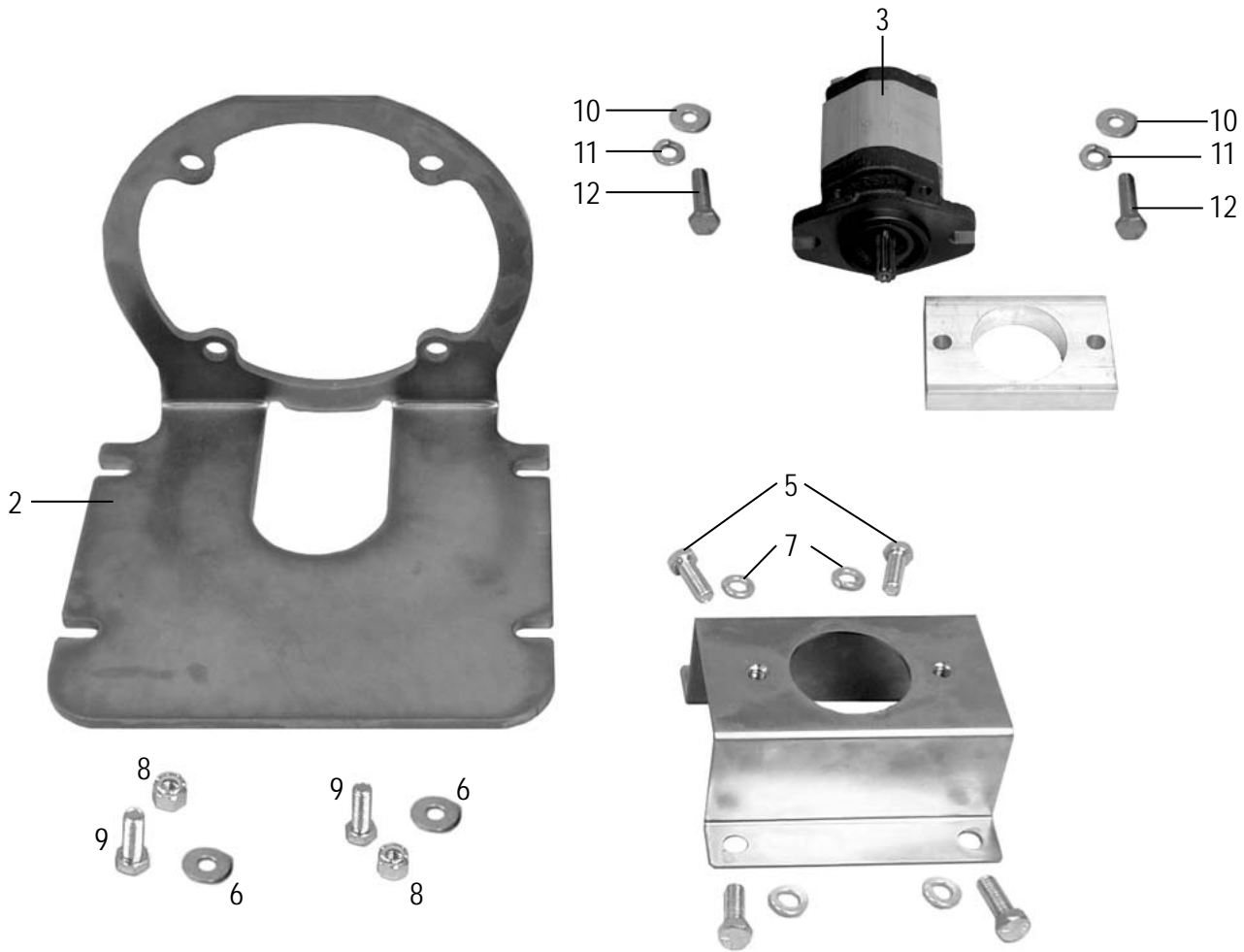

PART#	DESCRIPTION	QTY	PART#	DESCRIPTION	QTY
1	5110-6D	2	7	73204	3/8 SPLIT LOCK WASHER
2	5110-200	2	8	73207	3/8-16 NYLON LOCK NUT
3	70925	2	9	73236	3/8-16 X 1 HEXHEAD BOLT
4	73130	2	10	73302	5/16 FLAT WASHER
5	73201	8	11	73303	5/16 SPLIT LOCK WASHER
6	73203	8	12	73307	5/16-18 X 1 HEXHEAD BOLT

# Parts List and Diagrams

## WHEEL PARTS

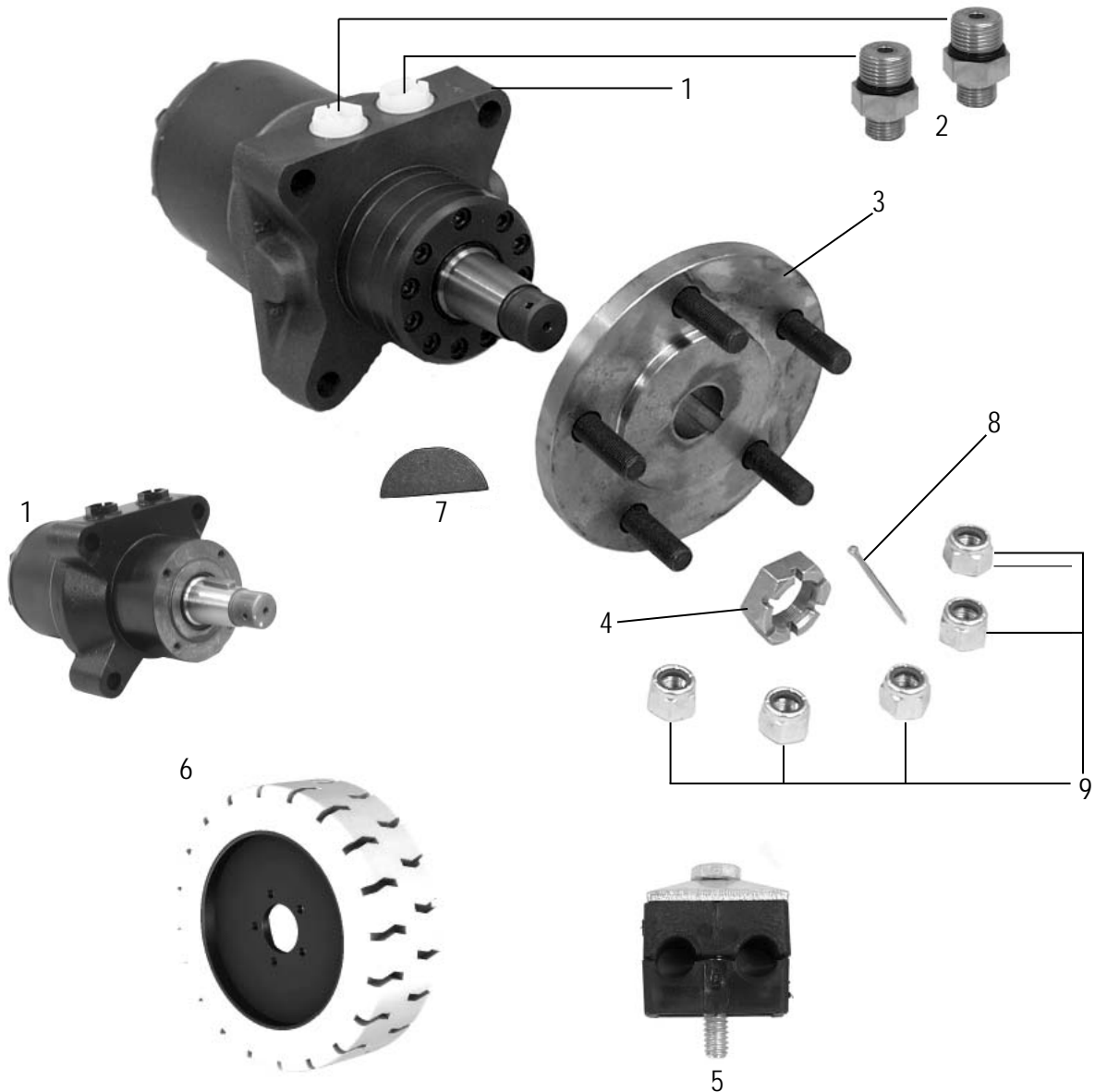

PART#	DESCRIPTION	QTY	PART#	DESCRIPTION	QTY		
1	400133	MOTOR, WHEEL, HYDRAULIC, 10MM	2	7	73047	¼ X 1 WOODRUFF KEY	1
2	5110-114-2	WHEEL MOTOR FITTING	4	8	73105	1/8 X 2 COTTER PIN	2
3	5110-117	WHEEL HUB	2	9	73430	1/2-20 NYLON LOCK NUT	10
4	5110-117-2	HUB NUT	2				
5	5110-261-1	WHEEL MOTOR HOSE CLAMP ASSEMBLY	2				
6	5110-405	18" WHEEL RIM & TIRE	2				

# Parts List and Diagrams

## CONTROL LEVER PARTS

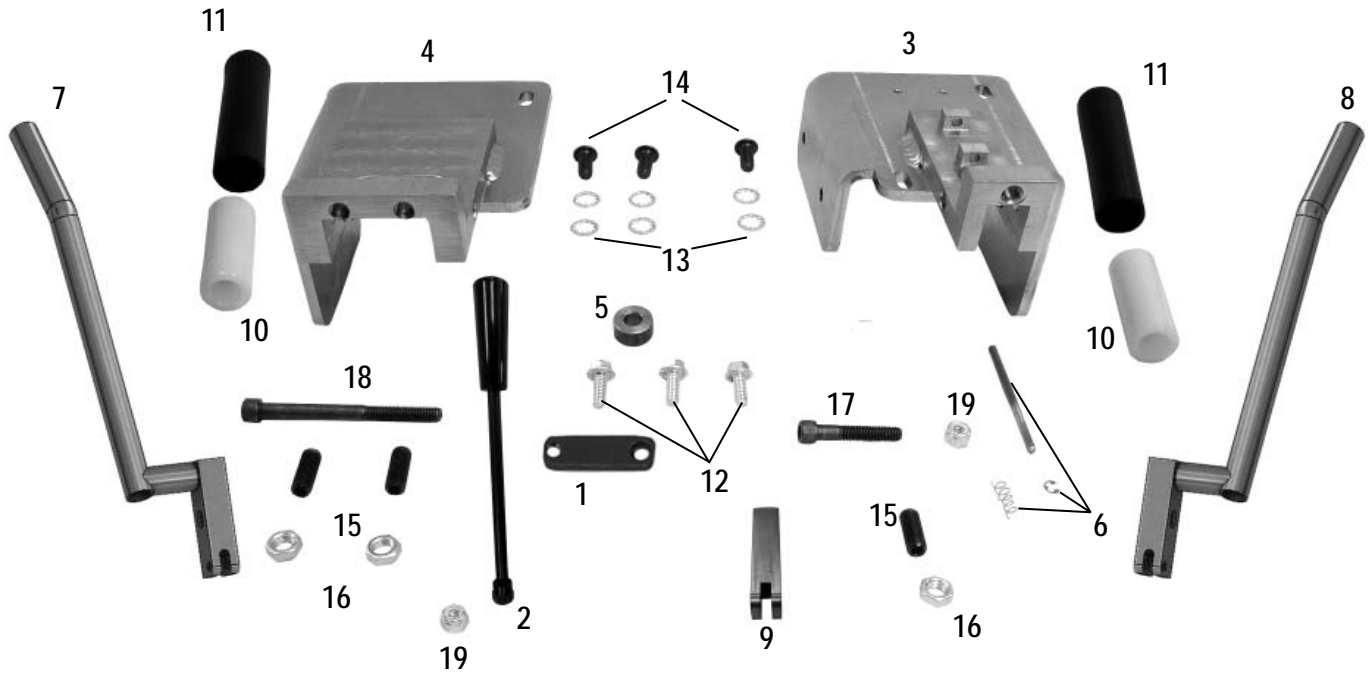

PART#	DESCRIPTION	QTY	PART#	DESCRIPTION	QTY
1	5110-271 LEVER BRACKET	1	11	400327 HANDLE RUBBER COVER	2
2	5110-272 CYLINDER LIFT LEVER ONLY	1	12	73020 1/4-20 X 5/8 WIZLOCK BOLT	3
3	5200QL-11-LH-W SINGLE SPOOL VALVE	1	13	73202 3/8 INTERNAL LOCK WASHER	6
4	5200QL-11-RH-W DOUBLE SPOOL VALVE	1	14	73213 3/8-16 X 3/4 BUTTON HEAD CAP SCREW	3
5	5200QL-13 VALVE LEVER SPACER	1	15	73227 3/8-24 X 1 SET SCREW	3
6	5200QL-14 BACKUP BEEPER PIN ASSEMBLY	1	16	73235 3/8-24 JAMB NUT	3
7	5600-21 HANDLE WELDMENT, LEFT	1	17	73320 5/16-18 X 2 SOCKET HEAD CAP SCREW	1
8	5600-22 HANDLE WELDMENT, RIGHT	1	18	73321 5/16-18 X 3 1/2 SOCKET HEAD CAP SCREW	1
9	5600-58 VALVE LEVER - SHORT	1	19	73322 5/16 NYLON LOCK NUT	2
10	5700-54 HANDLE GRIP SLEEVE	2			

# Parts List and Diagrams

## SINGLE SPOOL & HOSE PARTS

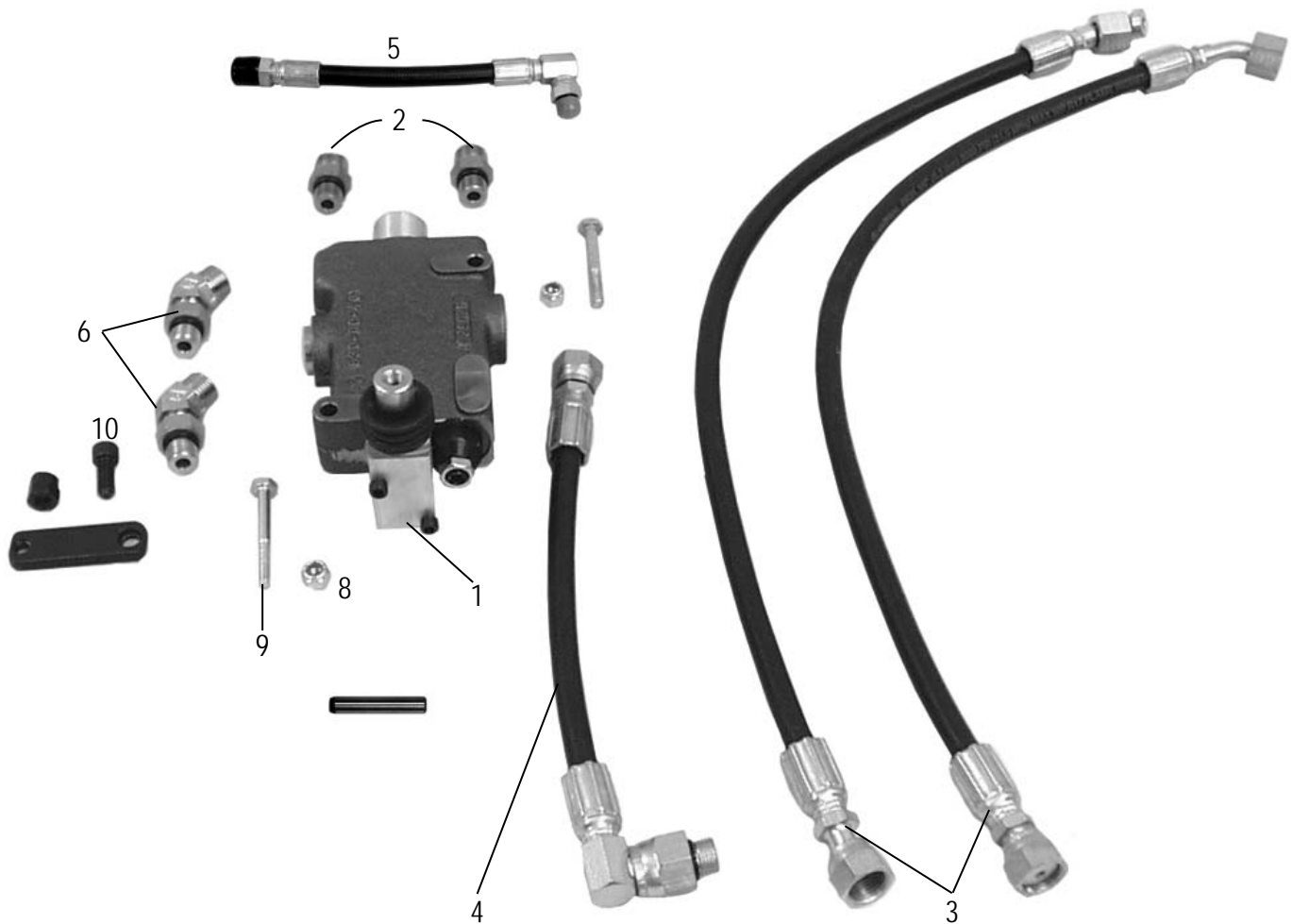

PART#	DESCRIPTION	QTY	PART#	DESCRIPTION	QTY		
1	5110-115	SINGLE SPOOL CONTROL	1	6	5110-264	45° VALVE FITTING	2
2	5110-268	STRAIGHT VALVE FITTING	2	7	72816	3/8 90° PUMP FITTING (NOT SHOWN)	1
3	5200-261	WHEEL MOTOR LINE	4	8	73008	1/4-20 NYLON LOCK NUT	4
4	5200-262	PRESSURE LINE	2	9	73021	1/4-20 X 2¼ HEXHEAD BOLT	4
5	5700-77	SUCTION LINE	2	10	73308	5/16-18 X 3/4 BUTTON HEAD CAP SCREW	2

# Parts List and Diagrams

## DOUBLE SPOOL & HOSE PARTS

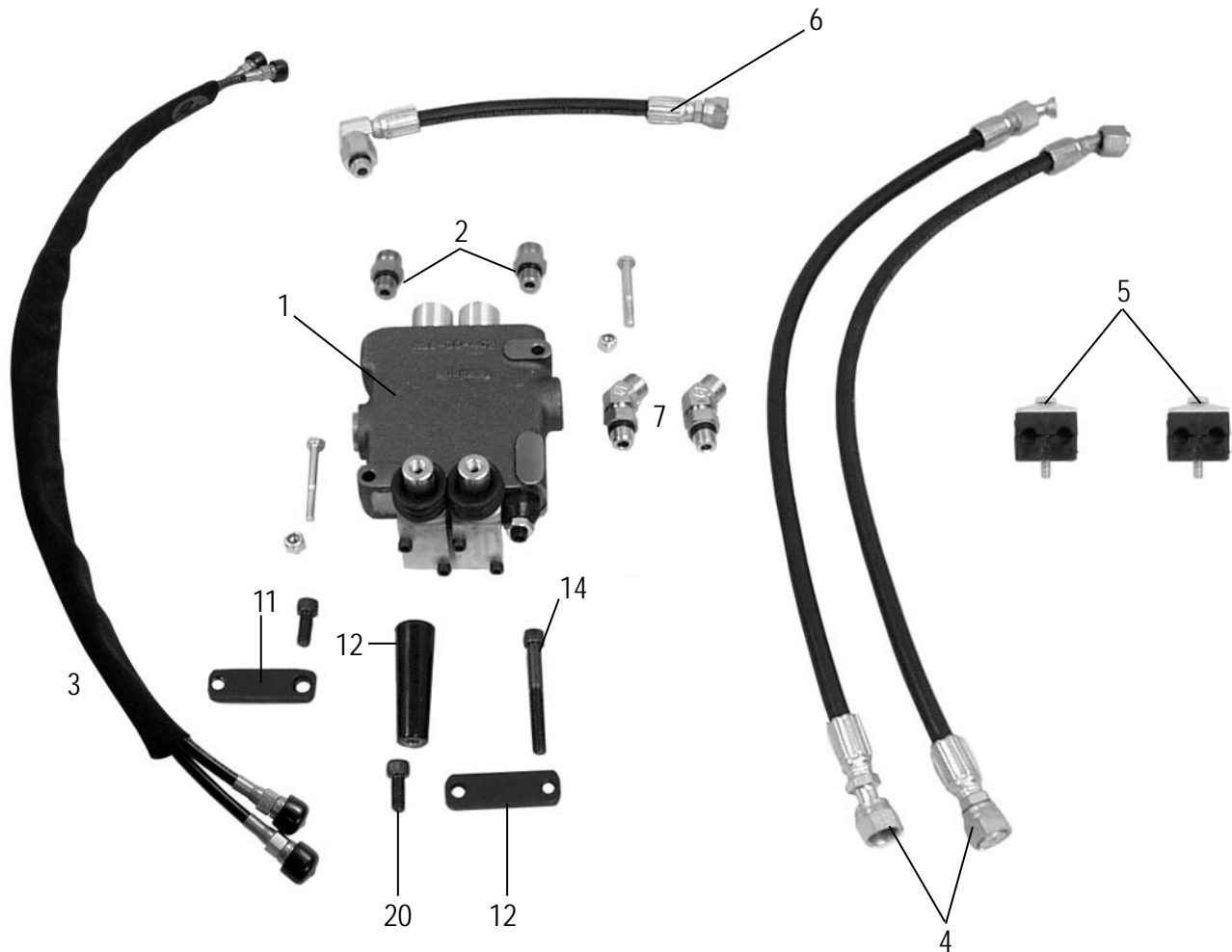

PART#	DESCRIPTION	QTY	PART#	DESCRIPTION	QTY		
1	5110-116	DOUBLE SPOOL CONTROL	1	9	5110-270	MOTION CONTROL LEVER	2
2	5110-219	STRAIGHT VALVE FITTING	2	10	5110-270-2	LEVER JAMB NUT 5/16	2
3	5110-267	HOSE, CYLINDER	1	11	5110-271	LEVER BRACKET	3
4	5200-261	WHEEL MOTOR HOSE	4	12	5110-272	CYLINDER LIFT LEVER ONLY	1
5	5110-261-1	WHEEL MOTOR HOSE CLAMP ASSEMBLY	2	13	73308	5/16-18 X 3/4 BUTTON HEAD SOCKET	2
6	400099	HOSE, SUCTION, 1/2" X 20" W/ F	2	14	73324	5/16-18 X 3/4 SOCKET HEAD CAP SCREW	1
7	70652	FITTING	2				
8	5110-268	FITTING, VALVE STRAIGHT (NOT SHOWN)	2				

# Parts List and Diagrams

## SLIDE PLATE & CYLINDER PARTS

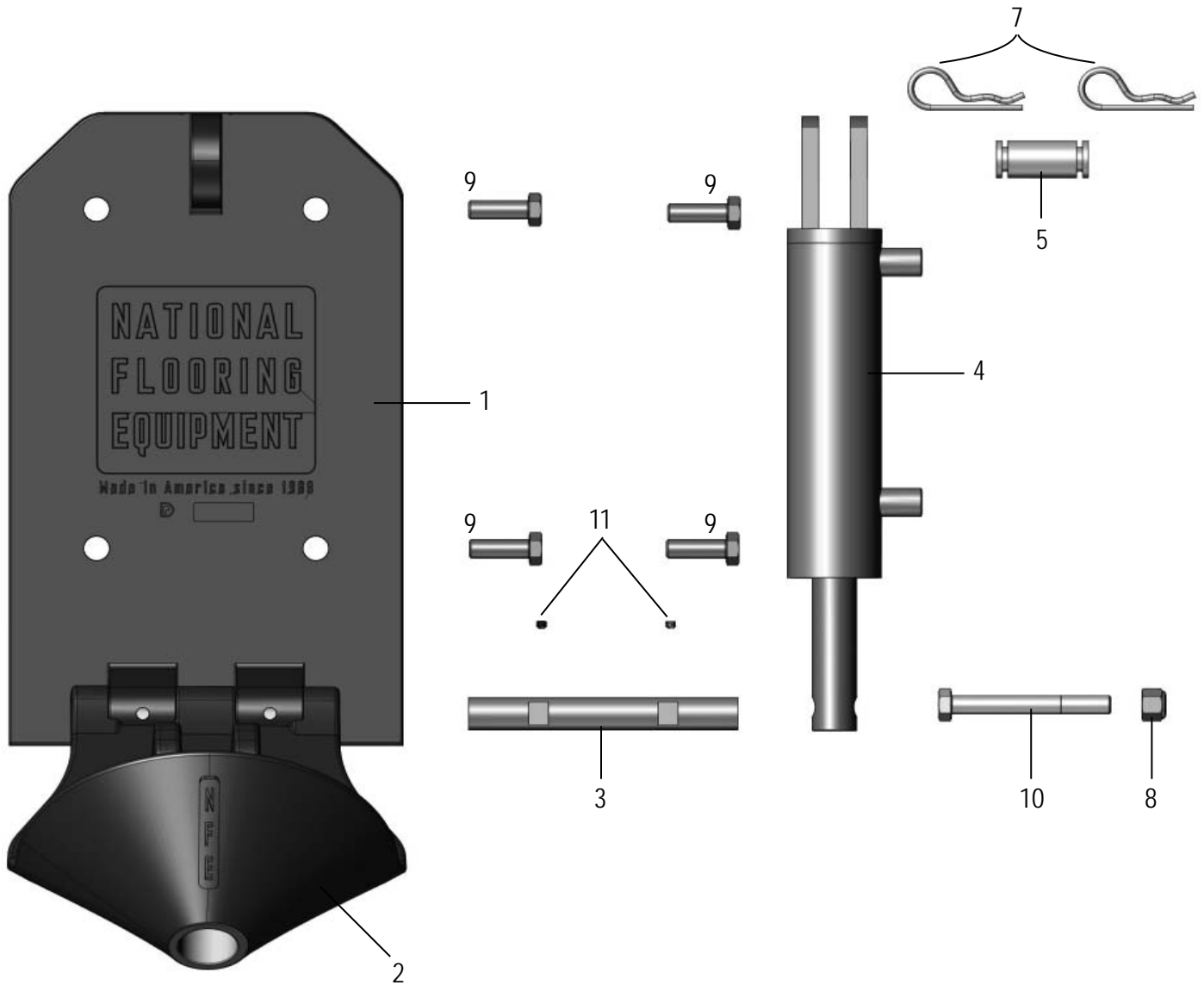

PART#	DESCRIPTION	QTY	PART#	DESCRIPTION	QTY		
1	401567	SLIDE PLATE	1	6	5110-251	CYLINDER CONNECTING ROD	1
2	401568	LOWER CUTTING HEAD SUPPORT	1	7	73536	CYLINDER CLIP	2
3	401429	PIN, LOWER CUTTING HEAD SUPPORT	1	8	73402	1/2-13 NYLON LOCK NUT	1
4	5110-250	CYLINDER	1	9	73027	BOLT, FLANGE 1/4-20X3/4	4
5	5110-250-3	CYLINDER SEAL KIT REPLACEMENT (NOT SHOWN)	1	10	400132	1/2-13 X 3 1/2 HEXHEAD BOLT	1
				11	401876	SSS, 3/8-24 X .25, BLACK OXIDE	2

# Parts List and Diagrams

## CASTER & FOOT PEG PARTS

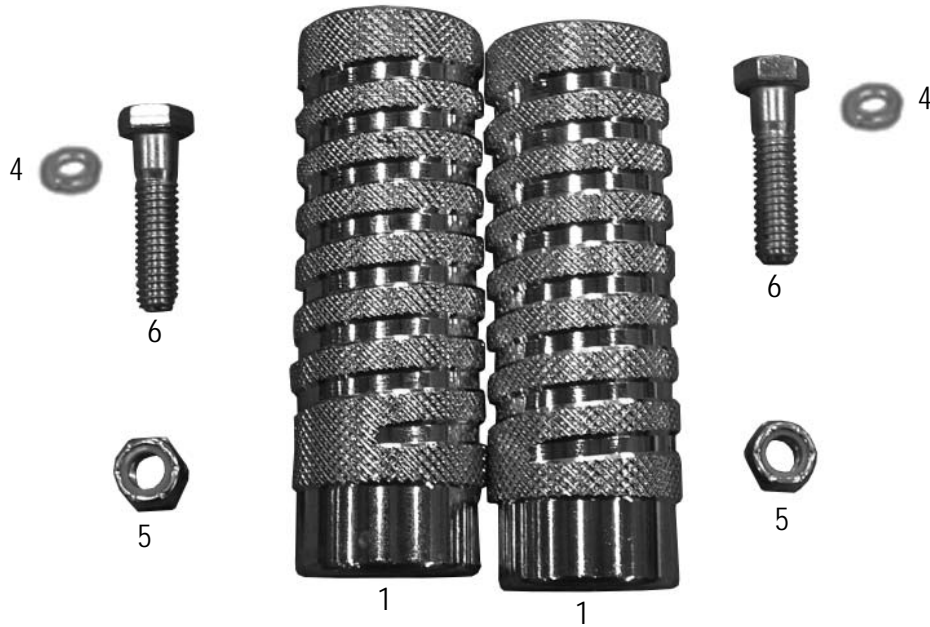
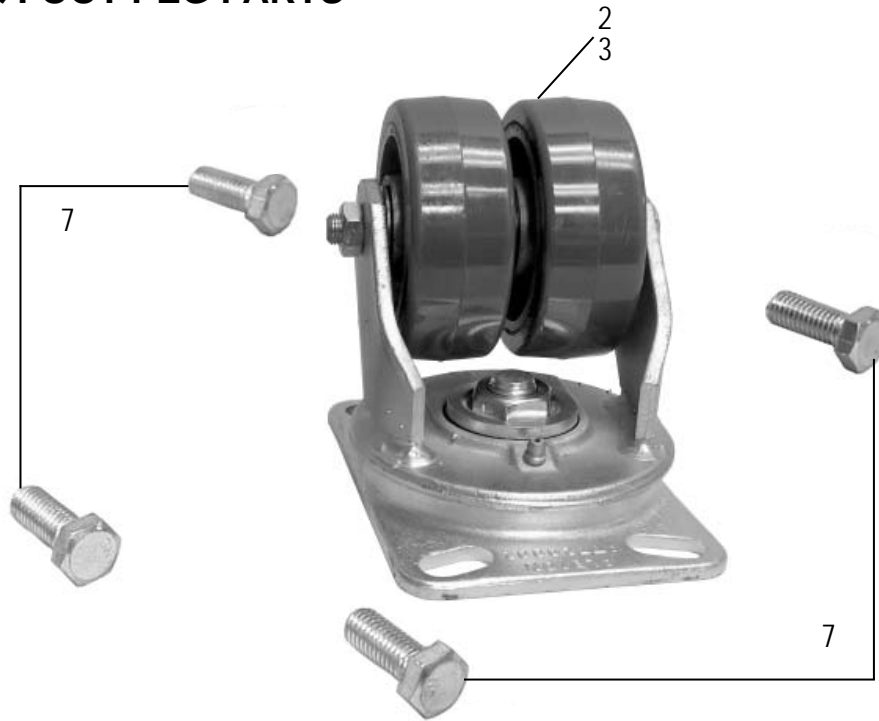

PART#	DESCRIPTION	QTY	PART#	DESCRIPTION	QTY		
1	5110-180	FOOT PEG	2	5	73207	3/8-16 NYLON LOCK NUT	2
2	5200-194	CASTER, DOUBLE-GRAY	1	6	73208	3/8-16 X 1½ HEXHEAD CAP SCREW	2
3	5200-194A	WHEEL, REPLACEMENT	2	7	73427	BOLT, HEXHEAD CAP 1/2-13X1-1/2	4
4	73204	3/8 SPLIT LOCK WASHER	2				

# Parts List and Diagrams

## FILTER AND TANK PARTS

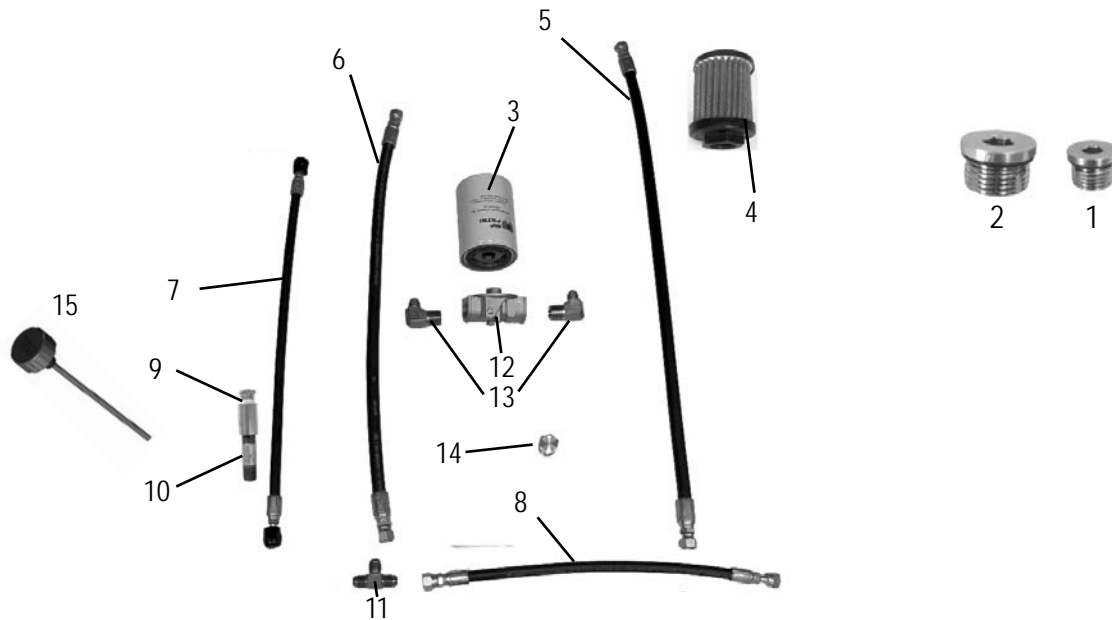

PART#	DESCRIPTION	QTY	PART#	DESCRIPTION	QTY
1	5110-156 OIL LEVEL PLUG	2	9	5110-234 COUPLER, RELIEF VALVE	1
2	5110-157 DRAIN/FILL PLUG	2	10	5110-234-1 PIPE, RELIEF VALVE	1
3	5700-65 FILTER	1	11	5700-70 T FITTING	1
4	5110-237 FILTER SCREEN	1	12	5700-66 FILTER HEAD	1
5	70359 HOSE, 3/4", RETURN LINE TO TANK	1	13	5700-64 FITTING, FILTER	1
6	70358 HOSE, 3/4", RETURN LINE TO FILTER	1	14	5700-67 PLUG, TANK	1
7	5700-71 HOSE, RETURN RIGHT	1	15	80058 DIPSTICK	1
8	5700-77 HOSE, RETURN LEFT	1			

# Parts List and Diagrams

## WEIGHT PARTS

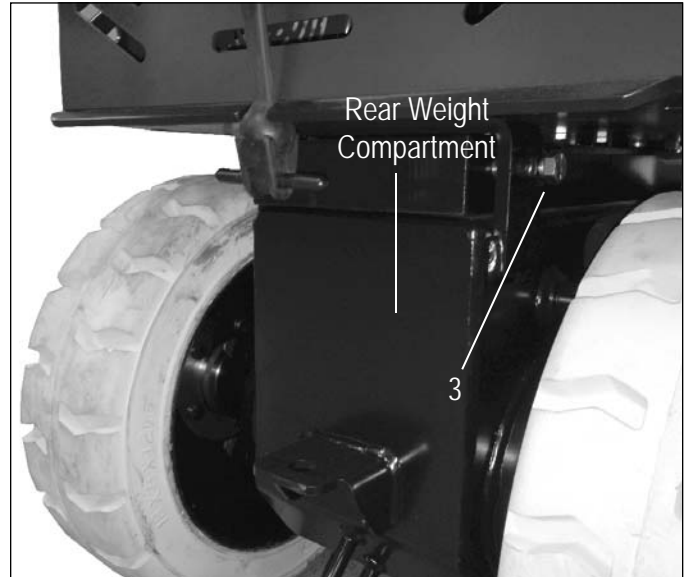
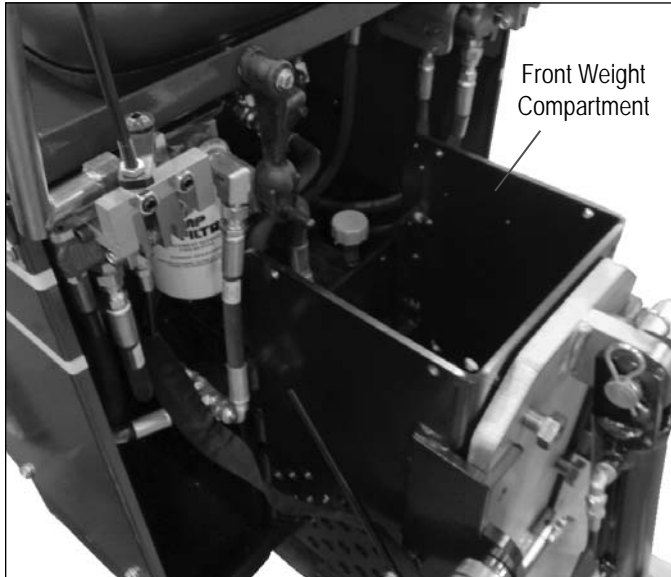

PART#	DESCRIPTION	QTY
1 74854	FRONT WEIGHT INDIVIDUAL	1
2 5110-404	REAR WEIGHT	1

PART#	DESCRIPTION	QTY
3 73406	1/2-13 X 1 1/4 HEXHEAD BOLT	1

# Parts List and Diagrams



## #7074 TILE BOX

The Tile Box works for wind rowing and assists for a fast clean-up and collection of tile debris for quick removal. High abrasion alloy for a long lasting edge. Resharpens just like a blade. 5" x 27" x 6" box. Attaches to the #7050-27 Cutting Head (required).



## #5110-100 FRONT WHEEL ASSEMBLY

Allows stability and safe transportation over any surface. Easy and quick to attach.

#5110-100W Replacement Wheel Only

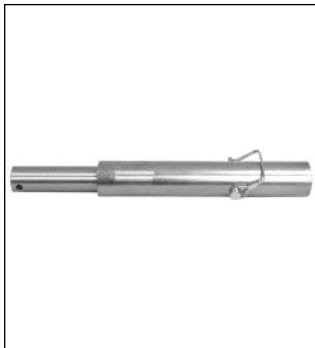

## #7050-15 CUTTING HEAD EXTENSION

Extension for cutting heads to reach under tight areas.



## #5110-111-3 OPTIONAL ARM RESTS/ SET

Optional Arm Rests for added comfort. Set includes left and right arm rest and mounting hardware.



# Parts List and Diagrams

## CONTROL BOX WIRING DIAGRAM

TOP VIEW

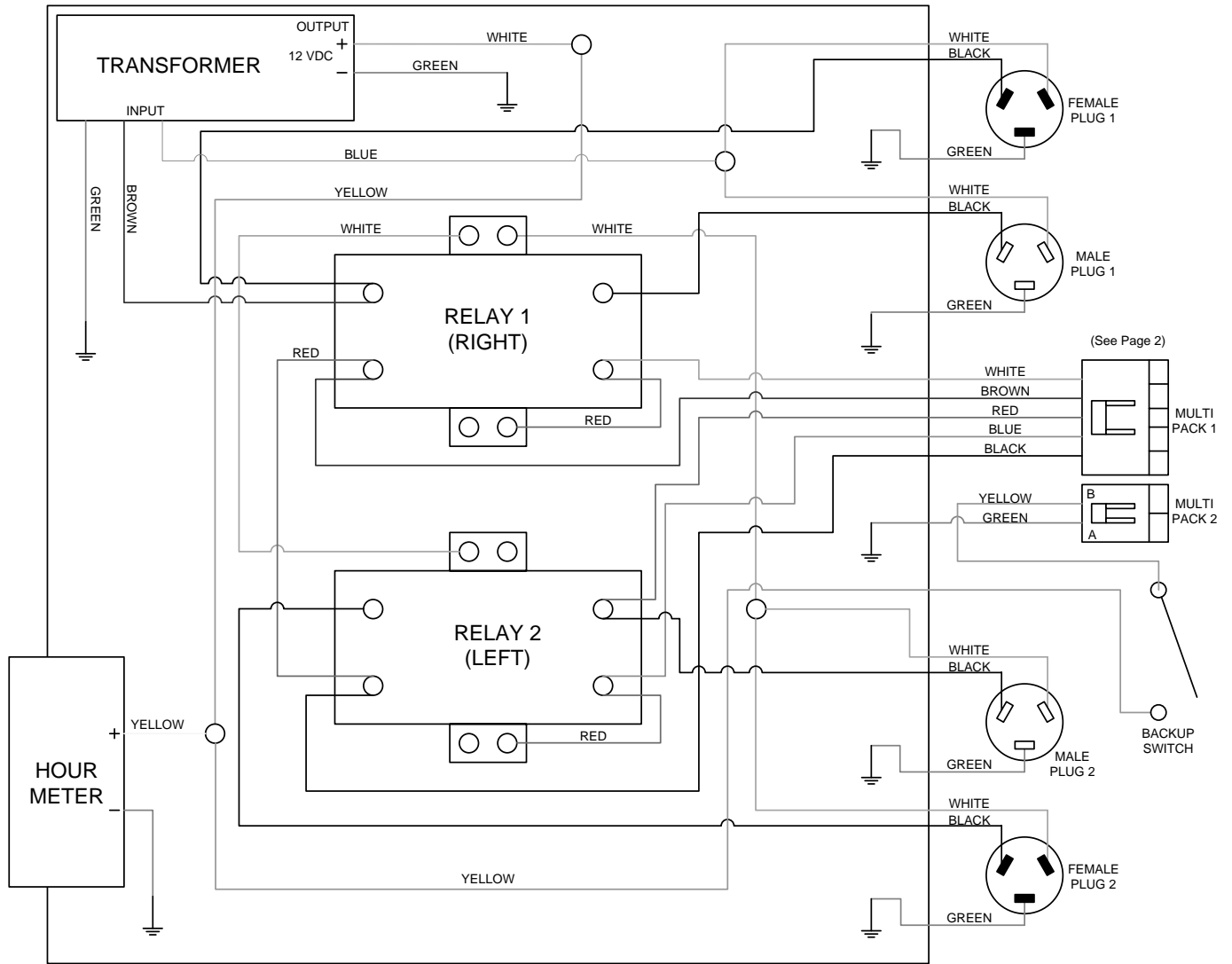

# Parts List and Diagrams

## SEAT SWITCH DIAGRAM

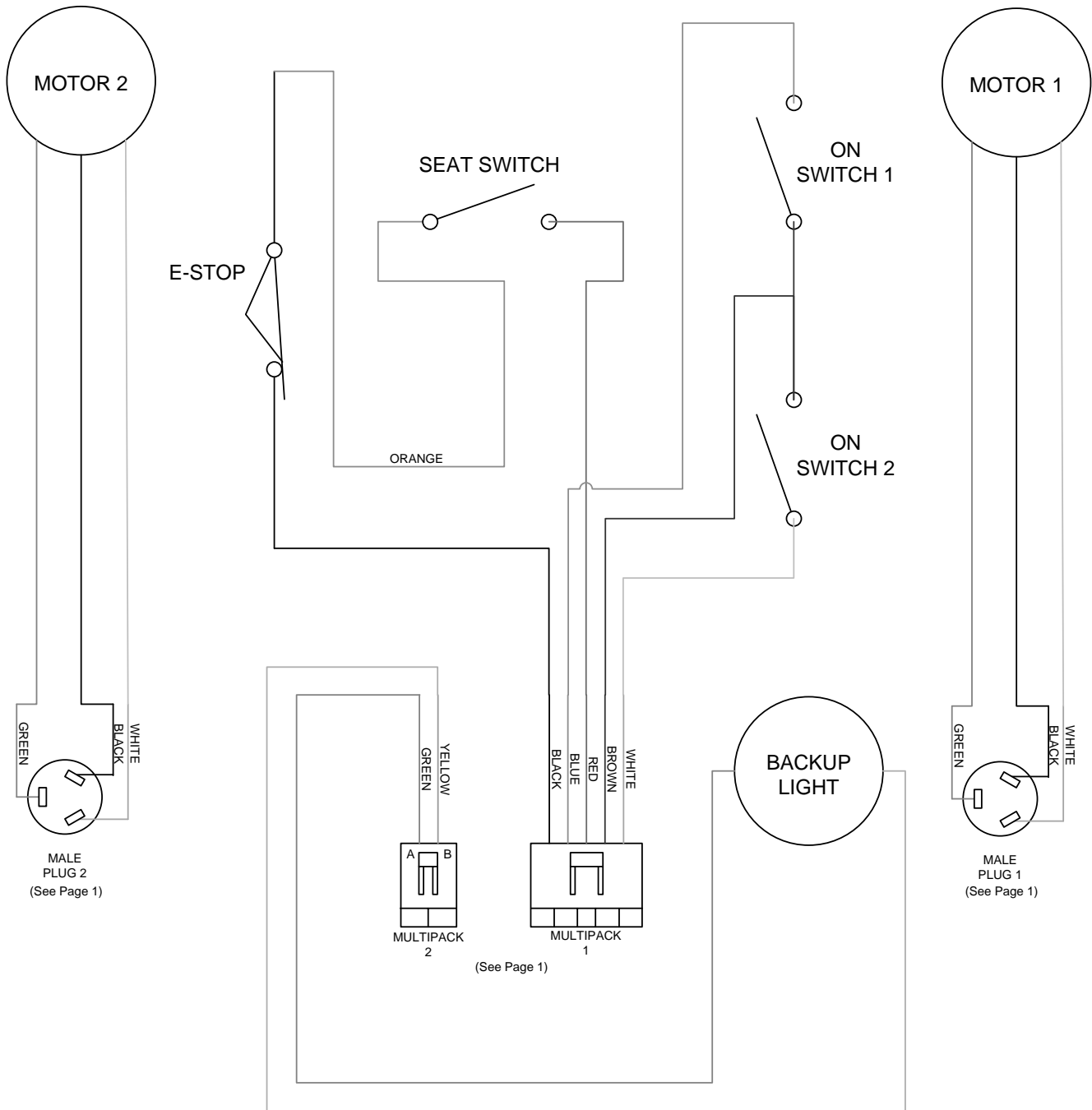

# Material Safety Data Sheet (MSDS) Information

## CHEVRON HD 22 - 68 - HYDRAULIC FLUID

### PRODUCT IDENTIFICATION AND COMPANY IDENTIFICATION

Product Number(S): CPS221655, CPS221658, CPS221659

Synonyms: Texaco Rando HD22, Texaco Rando HD 32, Texaco Rando HD 46, Texaco Rando HD 68

#### Company Information

Chevron Products Company  
a division of Chevron U.S.A. Inc.

6001 Bollinger Canyon Road

San Ramon, CA 94583

United States of America

www.chevronlubricants.com

Transportation Emergency Response

CHEMTREC: (800) 424-9300 or (703) 527-3887

Health Emergency

Chevron Emergency Information Center: Located in the USA.

International collect calls accepted.

(800) 231-0623 or (510) 231-0623

Product Information

email: lubemsds@chevron.com

Product Information: 800-LUBE-TEK

MSDS Requests: 800-414-6737

### HAZARDOUS INGREDIENTS / IDENTIFY INFORMATION

MATERIALS/COMPONENTS	CAS NUMER	AMOUNT
Highly Refined Mineral Oil (C15 - C50)	mixture	90-100% weight

### IMMEDIATE HEALTH EFFECTS

**Eye:** Not expected to cause prolonged or significant eye irritation.

**Skin:** Contact with the skin is not expected to cause prolonged or significant irritation. Not expected to be harmful to internal organs if absorbed through the skin. High-Pressure Equipment Information: Accidental high-velocity injection under the skin of materials of this type may result in serious injury. Seek medical attention at once should an accident like this occur. The initial wound at the injection site may not appear to be serious at first; but, if left untreated, could result in disfigurement or amputation of the affected part.

**Ingestion:** Not expected to be harmful if swallowed.

**Inhalation:** Not expected to be harmful if inhaled. Contains a petroleum-based mineral oil. May cause respiratory irritation or other pulmonary effects following prolonged or repeated inhalation of oil mist at airborne levels above the recommended mineral oil mist exposure limit. Symptoms of respiratory irritation may include coughing and difficulty breathing.

### FIRST AID MEASURES

**Eye:** No specific first aid measures are required. As a precaution, remove contact lenses, if worn, and flush eyes with water.

**Skin:** No specific first aid measures are required. As a precaution, remove clothing and shoes if contaminated. To remove the material from skin, use soap and water. Discard contaminated clothing and shoes or thoroughly clean before reuse.

**Ingestion:** No specific first aid measures are required. Do not induce vomiting. As a precaution, get medical advice.

**Inhalation:** No specific first aid measures are required. If exposed to excessive levels of material in the air, move the exposed person to fresh air. Get medical attention if coughing or respiratory discomfort occurs.

**Note to Physicians:** In an accident involving high-pressure equipment, this product may be injected under the skin. Such an accident may result in a small, sometimes bloodless, puncture wound. However, because of its driving force, material injected into a fingertip can be deposited into the palm of the hand. Within 24 hours, there is usually a great deal of swelling, discoloration, and intense throbbing pain. Immediate treatment at a surgical emergency center is recommended.

### FIRE FIGHTING MEASURES

Leaks/ruptures in high pressure system using materials of this type can create a fire hazard when in the vicinity of ignition sources (eg. open flame, pilot lights, sparks, or electric arcs).

**FIRE CLASSIFICATION:** OSHA Classification (29 CFR 1910.1200): Not classified by OSHA as flammable or combustible.

**NFPA RATINGS:** Health: 0 Flammability: 1 Reactivity: 0

### FLAMMABLE PROPERTIES:

Flashpoint: (Cleveland Open Cup) 150 C (302 F) (Min)

Autoignition: No Data Available

Flammability (Explosive) Limits (% by volume in the air): Lower: Not Applicable Upper: Not Applicable

# Material Safety Data Sheet (MSDS) Information

## CHEVRON HD 22 - 68 - HYDRAULIC FLUID (CONTINUED)

**EXTINGUISHING MEDIA:** Use water fog, foam, dry chemical or carbon dioxide (CO<sub>2</sub>) to extinguish flames.

**PROTECTION OF FIRE FIGHTERS:** Fire Fighting instructions: This material will burn although it is not easily ignited. For fires involving this material, do not enter any enclosed or confined fire space without proper protective equipment, including self-contained breathing apparatus.

**Combustion Products:** Highly dependent on combustion conditions. A complex mixture of airborne solids, liquids, and gases including carbon monoxide, carbon dioxide, and unidentified organic compounds will be evolved when this material undergoes combustion.

### ACCIDENTAL RELEASE MEASURES

**Protective Measures:** Eliminate all sources of ignition in vicinity of spilled material.

**Spill Management:** Stop the source of the release if you can do it without risk. Contain release to prevent further contamination of soil, surface water or groundwater. Clean up spill as soon as possible, observing precautions in Exposure Controls/Personal Protection. Use appropriate techniques such as applying non-combustible absorbent materials or pumping. Where feasible and appropriate, remove contaminated soil. Place contaminated materials in disposable containers and dispose of in a manner consistent with applicable regulations.

**Reporting:** Report spills to local authorities and/or the U.S. Coast Guard's National Response Center at (800) 424-8802 as appropriate or required.

### HANDLING AND STORAGE

**Precautionary Measures:** DO NOT USE IN HIGH PRESSURE SYSTEMS in the vicinity of flames, sparks and hot surfaces. Use only in well ventilated areas. Keep container closed.

**General Handling Information:** Avoid contaminating soil or releasing this material into sewage and drainage systems and bodies of water.

Electrostatic charge may accumulate and create a hazardous condition when handling this material. To minimize this hazard, bonding and grounding may be a necessary but may not, by themselves, be sufficient. Review all operations which have the potential of generating and accumulating an electrostatic charge and/or a flammable atmosphere (including tank and container filling, splash filling, tank cleaning, sampling, gauging, switch loading, filtering, mixing, agitation, and vacuum truck operations) and use appropriate mitigating procedures. For more information, refer to OSHA standard 29 CFR 1910.106, 'Flammable and Combustible Liquids', National Fire Protection Association (NFPA 77, 'Recommended Practice on Static Electricity', and/or the American Petroleum Institute (API) Recommended Practice 2003, 'Protection Against Ignitions Arising Out of Static, Lightning, and Stray Currents'.

**Container Warnings:** Container is not designed to contain pressure. Do not use pressure to empty container or it may rupture with explosive force. Empty containers retain product residue (solid, liquid, and/or vapor) and can be dangerous. Do not pressurize, cut, weld, braze, solder, drill, grind, or expose such containers to heat, flame, sparks, static electricity, or other sources of ignition. They may explode and cause injury or death. Empty containers should be completely drained, properly closed, and promptly returned to a drum reconditioner or disposed of properly.

### EXPOSURE CONTROLS/PERSONAL PROTECTION

**GENERAL CONSIDERATIONS:** Consider the potential hazards of this material (see Section 3), applicable exposure limits, job activities, and other substances in the workplace when designing engineering controls and selecting personal protective equipment. If engineering controls or work practices are not adequate to prevent exposure to harmful levels of this material, the personal protective equipment listed below is recommended. The user should read and understand all instructions and limitations supplied with the equipment since protection is usually provided for a limited time or under certain circumstances.

**ENGINEERING CONTROLS:** Use in a well-ventilated area.

### PERSONAL PROTECTIVE EQUIPMENT

**Eye/Face Protection:** No special eye protection is normally required. Where splashing is possible, wear safety glasses with side shields as a good safety practice.

**Skin Protection:** No special protective clothing is normally required. Where splashing is possible, select protective clothing depending on operations conducted, physical requirements and other substances in the workplace. Suggested materials for protective gloves include: 4H (PE/EVAL), Nitrile Rubber, Silver Shield, Viton.

**Respiratory Protection:** No respiratory protection is normally required. If user operations generate an oil mist, determine if airborne concentrations are below the occupational exposure limit for mineral oil mist. If not, wear an approved respirator that provides adequate protection from measured concentrations of this material. For air-purifying respirators use a particulate cartridge. Use a positive pressure air-supplying respirator in circumstances where air-purifying respirators may not provide adequate protection.

# Chevron HD 22 - 68 - hydraulic fluid (continued)

## CHEVRON HD 22 - 68 - HYDRAULIC FLUID (CONTINUED)

### PHYSICAL AND CHEMICAL PROPERTIES

Attention: The data below are typical values and do not constitute a specification.

<b>Color:</b> Yellow	<b>Physical State:</b> Liquid	<b>Odor:</b> Petroleum odor
<b>pH:</b> Not applicable	<b>Vapor Pressure:</b> <0.01 mmHg @ 37.8 C (100 F)	<b>Vapor Density (Air = 1):</b> >1
<b>Boiling Point:</b> >315.6 C (600 F)	<b>Solubility:</b> Soluble in hydrocarbons; insoluble in water	<b>Freezing Point:</b> Not Applicable
<b>Melting Point:</b> Not Applicable	<b>Specific Gravity:</b> 0.86 - 0.87 @ 15.6 C (60.1 F) / 15.6 (60.1F)	<b>Density:</b> 0.86 kg/l - 0.9 kg/l @ 15 C (59 F)
<b>Viscosity:</b> 22 cSt - 61.2 cSt @40 C (104 F) (Min)		

### STABILITY AND REACTIVITY

**Chemical Stability:** This material is considered stable under normal ambient and anticipated storage and handling conditions of temperature and pressure.

**Incompatibility With Other Materials:** May react with strong acids or strong oxidizing agents, such as chlorates, nitrates, peroxides, etc.

**Hazardous Decomposition Products:** None known. (None expected)

**Hazardous Polymerization:** Hazardous polymerization will not occur.

### TOXICOLOGICAL INFORMATION

#### IMMEDIATE HEALTH EFFECTS

**Eye Irritation:** The eye irritation hazard is based on evaluation of data for similar materials or product components.

**Skin Irritation:** The skin irritation hazard is based on evaluation of data for similar materials or product components.

**Skin Sensitization:** No product toxicology data available.

**Acute Dermal Toxicity:** The acute dermal toxicity hazard is based on evaluation of data for similar materials or product components.

**Acute Oral Toxicity:** The acute oral toxicity hazard is based on evaluation of data for similar materials or product components.

**Acute Inhalation Toxicity:** The acute inhalation toxicity hazard is based on evaluation of data for similar materials or product components.

#### ADDITIONAL TOXICOLOGY INFORMATION

This product contains petroleum base oils which may be refined by various processes including severe solvent extraction, severe hydrocracking, or severe hydrotreating. None of the oils requires a cancer warning under the OSHA Hazard Communication Standard (29 CFR 1910.1200). These oils have not been listed in the National Toxicology Program (NTP) Annual Report nor have been classified by the International Agency for Research on Cancer (IARC) as; carcinogenic to humans (Group 1), probably carcinogenic to humans (Group 2), or possibly carcinogenic to humans (Group 2B). These oils have not been classified by the American Conference of Governmental Industrial Hygienists (ACGIH) as: confirmed human carcinogen (A1), suspected human carcinogen (A2), or confirmed animal carcinogen with unknown relevance (A3).

### ECOLOGICAL INFORMATION

#### ECOTOXICITY

This material is not expected to be harmful to aquatic organisms. The ecotoxicity hazard is based on an evaluation of data for the components of a similar material.

#### ENVIRONMENTAL FATE

This material is not expected to be readily biodegradable.

#### DISPOSAL CONSIDERATIONS

Use material for its intended purpose or recycle if possible. Oil collection services are available for used oil recycling or disposal. Place contaminated materials in containers and dispose of in a manner consistent with applicable regulations. Contact your sales representative or local environmental or health authorities for approved disposal or recycling methods.

#### TRANSPORT INFORMATION

The description shown may not apply to all shipping situations. Consult 49CFR, or appropriate Dangerous Goods Regulations, for additional description requirements (e.g., technical name) and mode-specific or quantity-specific shipping requirements.

**DOT Shipping Description:** PETROLEUM LUBRICATING OIL, NOT REGULATED AS A HAZARDOUS MATERIAL FOR TRANSPORTATION UNDER 49 CFR Additional Information: NOT HAZARDOUS BY U.S. DOT. ADR/RID HAZARD CLASS NOT APPLICABLE

**IMO/IMDG Shipping Description:** PETROLEUM LUBRICATING OIL; NOT REGULATED AS DANGEROUS GOODS FOR TRANSPORT UNDER THE IMDG CODE

**ICAO/IATA Shipping Description:** PETROLEUM LUBRICATING OIL; NOT REGULATED AS DANGEROUS GOODS FOR TRANSPORT UNDER ICAO

# Chevron HD 22 - 68 - hydraulic fluid (continued)

## REGULATORY INFORMATION

### EPCRA 311/312 CATEGORIES:

1. Immediate (Acute) Health Effects: NO
2. Delayed (Chronic) Health Effects: NO
3. Fire Hazard: NO
4. Sudden Release of Pressure Hazard: NO
5. Reactivity Hazard: NO

### REGULATORY LISTS SEARCHED:

- |                     |                      |
|---------------------|----------------------|
| 01-1=IARC Group1    | 03=EPCRA 313         |
| 01-2A=IARC Group 2A | 04=CA Proposition 65 |
| 01-2B=IARC Group 2  | 05=MA RTK            |
| 02=NTP Carcinogen   | 06=NJ RTK            |

No components of this material were found on the regulatory lists above.

### CHEMICAL INVENTORIES:

All components comply with the following chemical inventory requirements: AICS (Australia), DSL (Canada), ENCS (Japan), IECSC (China), KECI (Korea), PICCS (Philippines), TSCA (United States)

One or more components is listed on ELINCS (European Union). Secondary notification by the importer may be required.

### NEW JERSEY RTK CLASSIFICATION:

Under the New Jersey Right-to-Know Act L. 1983 Chapter 315 N.J.S.A. 34:5A-1 et. seq., the product is to be identified as follows: PETROLEUM OIL (Hydraulic oil)

### WHMIS CLASSIFICATION:

This product is not considered a controlled product according to the criteria of the Canadian Controlled Products Regulations.

### OTHER INFORMATION

**NFPA RATINGS:** Health: 0 Flammability: 1 Reactivity: 0

**HMIS RATINGS:** Health: 1 Flammability: 1 Reactivity: 0

(0-Least, 1-Slight, 2-Moderate, 3-High, 4-Extreme, PPE:- Personal Protection Equipment Index recommendation,\*-Chronic Effect Indicator). These values are obtained using the guidelines or published evaluations prepared by the National Fire Protection Association (NFPA) or the National Paint and Coating Association (for HMIS ratings).

**LABEL RECOMMENDATION:** Label Category: INDUSTRIAL OIL 1 - IND1

**REVISION STATEMENT:** This revision updates the following sections of this Material Safety Data Sheet:

**Revision Date:** January 15, 2007

### ABBREVIATIONS THAT MAY HAVE BEEN USED IN THIS DOCUMENT:

- |   |  |
|---|--|
| TLV - Threshold Limit Value                                     | TWA - Time weighted Average                        |
| STEL - Short-term Exposure Limit                                | PEL - Permissible Exposure Limit                   |
| CAS - Chemical Abstract Service Number                          | IMDG - International Maritime Dangerous Goods Code |
| API - American Petroleum Institute                              | MSDS - Material Safety Data Sheet                  |
| ACGIH - American Conference of Government Industrial Hygienists | CVX - Chevron                                      |
| NFPA - National Fire Protection Association (USA)               | DOT - Department of Transportation                 |
| NTPA - National Toxicology Program(USA)                         | IARC - International Agency for Research on Cancer |
| OSHA - Occupational Safety and Health Administration            |  |

Prepared according to the OSHA Hazard Communication Standard (29 CFR 1910.1200) and the ANSI MSDS Standard (Z400.1) by the Chevron Energy Technology Company, 100 Chevron Way, Richmond, California 94802.

The above information is based on the data of which we are aware and is believed to be correct as of the date hereof. Since this information may be applied under conditions beyond our control and with which we may be unfamiliar and since data made available subsequent to the date hereof may suggest modifications of the information, we do not assume any responsibility for the results of its use. This information is furnished upon condition that the person receiving it shall make his own determination of the suitability of the material for his particular purpose.



# Guarantee

---

National Flooring Equipment, Inc. (National) warrants to the first consumer/purchaser that this National brand product (5110 Electric Ride-On Floor Prep System) when shipped in its original container, will be free from defective workmanship and materials and agrees that it will, at its option, either repair the defect or replace the defective product or part thereof at no charge to the purchaser for parts or labor for the period(s) set forth below.

This warranty does not apply to any appearance items of the product, to the additional excluded items set forth below, or to any product, the exterior of which has been damaged or defaced, which has been subjected to misuse, abnormal service or handling, or which has been altered or modified in design or construction.

In order to enforce the rights under this limited warranty, the purchaser should follow the steps set forth below and provide proof of purchase to National.

The limited warranty described herein is in addition to whatever implied warranties may be granted to purchasers by law. All implied warranties including the warranties of merchantability and fitness for use are limited to the periods from the date of purchase as set forth below. Some states do not allow time limitations on an implied warranty, so the above limitation may not apply to you.

Neither the sales person of the seller, nor any other person, is authorized to make any other warranties other than those described herein, or to extend the duration of any warranties beyond the time period described herein on behalf of National.

The warranties described herein shall be the sole and exclusive warranties granted by National and shall be the sole and exclusive remedy available to the purchaser. Correction of defects in the manner and for the period of time described herein, shall constitute complete fulfillment of all liabilities and responsibilities of National to the purchaser with respect to the product and shall constitute full satisfaction of all claims, whether based on contract, negligence, strict liability or otherwise. In no event shall National be liable, or in any way responsible for any damage or defects in the product which were caused by repairs or attempted repairs performed by anyone other than National. Nor shall National be liable, or in any way responsible, for any incidental or consequential, economics or property damage. Some states do not allow the exclusion of incidental or consequential damages, so the above exclusion may not apply to you.

This warranty gives you specific legal rights. You may also have other rights which vary from state to state.

## **WARRANTY PERIOD**

The 5110 Electric Ride-On Floor Prep System is guaranteed to be free of manufacturer defective workmanship and in quality of materials for a period of one year.

Items excluded from warranty coverage, unless found and reported defective immediately upon removal from the original shipping container and before being used by the original purchaser.

A freight damage claim must be filed with the carrier by the purchaser, the shipper cannot file the freight claim.

**TO OBTAIN SERVICE CONTACT NATIONAL FLOORING EQUIPMENT, INC. TOLL FREE AT 800-245-0267 FOR A REPAIR AUTHORIZATION NUMBER. COD FREIGHT RETURNS WILL NOT BE ACCEPTED. FREIGHT COLLECT SHIPMENTS WILL NOT BE ACCEPTED. WARRANTY REPAIRS MUST BE ACCOMPANIED BY DATE OF PURCHASE RECEIPT AND A RETURN/REPAIR AUTHORIZATION NUMBER.**

**RETURN/REPAIR AUTHORIZATION NUMBER:** \_\_\_\_\_

**MACHINE SERIAL NUMBER:** \_\_\_\_\_



Made in America Since 1968

9250 Xylon Avenue N • Minneapolis, MN 55445 • U.S.A.  
Toll-free 800-245-0267 • Phone 763-315-5300 • Fax 800-648-7124 • Fax 763-535-8255  
Web Site: [www.nationalequipment.com](http://www.nationalequipment.com) • E-Mail: [info@nationalequipment.com](mailto:info@nationalequipment.com)